



BUTERE GIRLS NATIONAL SCHOOL 2025 MOCK EXAMS



Kenya Certificate of Secondary Education



BUTERE GIRLS NATIONAL SCHOOL **2025 MOCK EXAMS** *(ALL SUBJECTS TESTED)*



BUTERE GIRLS NATIONAL SCHOOL **2025 MOCK EXAMS**

Prefer Calling Amobi Group of Examiners @

0743 333 000 or 0706 851 439

For Marking Schemes

N/B In Response to the Huge Costs Associated in Coming Up with Such/Similar Resources ***Regularly***, We inform us All, **MARKING SCHEMES ARE NOT FREE OF CHARGE**. However Similar **QUESTIONS**, Inform of **soft Copies**, are Absolutely **FREE** to **Anybody/Everybody**. Hence **NOT FOR SALE**

by Amobi Group of Examiners.

Amobi Group Of Examiners

Call Us @

0743 333 000 or 0706 851 439

CALL 0743 333 000 OR 0706 851 439

📌 Mid/End Term, Pre/Mock Exams

📌 K.C.S.E Prediction/Forecast Exams

📌 F1-F4 All Subjects Notes/Topical Qsns

📌 Updated Schemes of Work/Syllabus

📌 Acted Set Books Videos/ Guides

📌 Set Books Essays/Excerpts Qsns

📌 Past K.C.S.E Papers & Holiday Assignments

📌 70 Biology Graphical/Essays Qsns

📌 70 Biology Pictorial Practical Qsns

📌 Poetry & Ushairi Qsns.... e.t.c

ORDER OF THE 12 SUBJECTS
TESTED (*ALPHABETICALLY ARRANGED*)

- 1. AGRICULTURE**
- 2. BIOLOGY**
- 3. BUSINESS STUDIES**
- 4. CHEMISTRY**
- 5. COMPUTER**
- 6. C.R.E**
- 7. ENGLISH**
- 8. GEOGRAPHY**
- 9. HISTORY**
- 10. KISWAHILI**
- 11. MATHS**
- 12. PHYSCIS**



BUTERE GIRLS' NATIONAL SCHOOL MOCK EXAMS 2025



Kenya Certificate of Secondary Education

NAME _____ ADM NO _____ CLASS _____

443/1
AGRICULTURE
PAPER 1

TIME: 2 HOURS

**Agriculture
Paper 1**

INSTRUCTIONS TO CANDIDATES:

- Write **your name and Index number and sign** in the spaces provided above.
- Answer **ALL** the questions in section **A and B** in the spaces provided in this booklet.
- Answer **any two** questions in section **C** in the spaces provided after the last question.

For Examiner's Use Only:

SECTION	QUESTIONS	MAXIMUM SCORE	CANDIDATES SCORE
A	1 –10	30	
B	11–13	20	
C	14-16	40	
	TOTAL	90	



SECTION A:

30MKS

Answer all questions in this section

1. State 2 characteristic of shifting cultivation 2mks

.....
.....

2. i) State 2 benefits of Agroforestry to a bean crop 2mks

.....
.....

ii) State 4 characteristic of good trees for Agroforestry 2mks

.....
.....

3. Name 4 financial documents used in farm accounting 2mks

.....
.....

4. State 3 reasons why early defoliation should be discouraged in pasture utilization 3mks

.....
.....

5. i) Distinguish between straight and compound fertilizer 2mks

.....
.....

ii) Give 3 reasons for applying phosphatic fertilizer during planting 3mks

.....
.....

6. Outline 3 cultural measures of controlling maize streak

3mks

.....

.....

.....

.....

7. State 3 ways in which HIV/AIDS limits Agriculture production

3mks

.....

.....

.....

.....

8. Outline 3 advantages of tenancy system in farming

3mks

.....

.....

.....

.....

9. Give 3 reasons for inter cropping

3mks

.....

.....

.....

.....

10. Give 3 reasons for controlling black jack in a field of maize

3mks

.....

.....

.....

.....

.....

Answer all questions in this section

11. The illustration below shows a method of soil water conservation

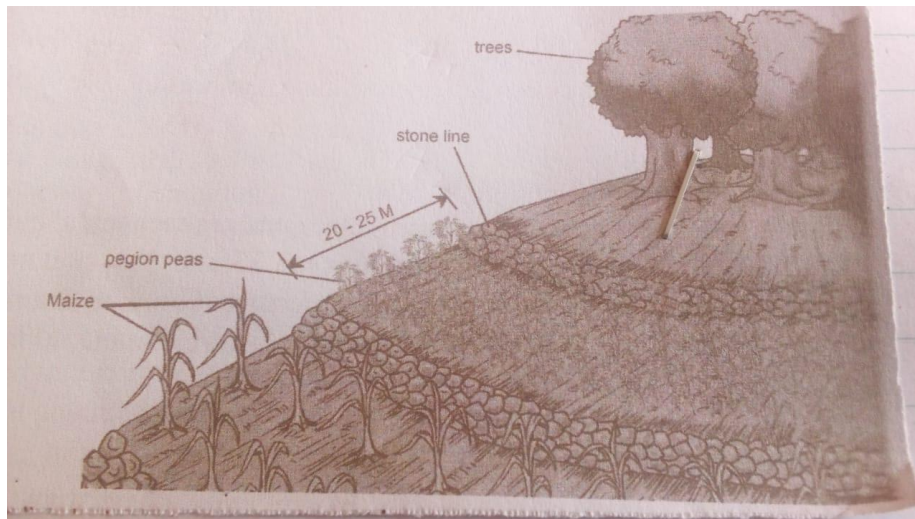

i) Identify the above method 1mk

.....

ii) Describe how the above method is attained 1mk

.....

.....

iii) State 2 ways in which the above method conserves soil and water 2mks

.....

.....

iv) Name any 3 types of micro-catchment 3mks

.....

.....

.....

.....

12. The diagram below shows a crop commonly grown by farmers

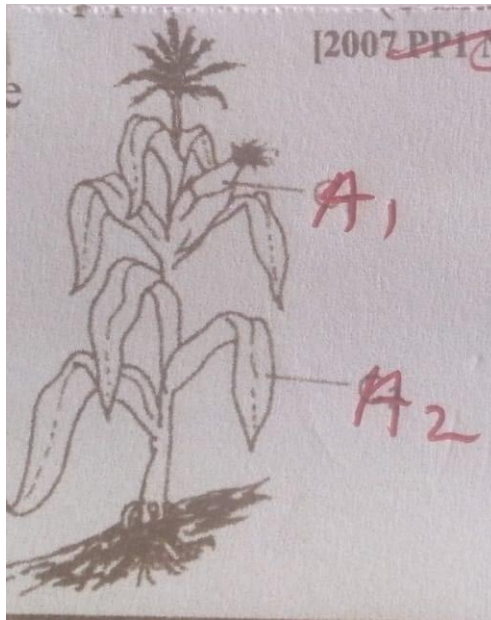

i) Name 2 pest that attack part A1 2mks

.....
.....

ii) Name 2 diseases that attack part labelled A2 2mks

.....
.....

iii) State 3 effects of pest with both piercing and sucking mouth on crop parts 3mks

.....
.....
.....
.....
.....

13. The diagram below shows a method of pegging. study and answer questions that follow





i. Identify the above methods

i).....

ii)

ii) Name 2 tools used in pruning

2mks

.....
.....

iii) Give 2 reasons for pruning tea

2mks

.....
.....
.....
.....
.....
.....

Answer any two questions in this section.

14. The information below was extracted from Ruto’s farm as at 30th September 2007

Debtors	16,000
Bank loan payable	60,000
Bank overdraft	30,000
Buildings	50,000
Creditors to the farm	10,000
Disc plough	16,000
Cash in hand	20,000
Land	60,000
Cash in bank	60,000
Working tool	10,000
Cattle	40,000

- i) Prepare a balance sheet for Ruto farm using above information 6mks
- ii) State whether the farm is solvent or insolvent 1mk
- iii) Describe various principles that allow formation of cooperative societies 9mks
- iv) Name 4 information contained in a tittle deed 4mks

15.a) Describe how coffee is harvested 7mks

b) Explain 7 harmful effects of pest on crops 7mks

c) Describe 6 risks and uncertainties in Agriculture 6mks

16.a) Explain 5 characteristic of crops used for making green manure 5mks

b) State 5 benefits of using certified seeds 5mks

c) Explain 5 problems faced by farmers who do not keep farm records 10mks

.....

.....

.....

.....

.....

.....

.....



BUTERE GIRLS' NATIONAL SCHOOL MOCK EXAMS 2025



Kenya Certificate of Secondary Education

NAME _____ ADM NO _____ CLASS _____

443/2
AGRICULTURE
PAPER 2

TIME: 2 HOURS

Agriculture Paper 2

INSTRUCTIONS TO CANDIDATES:

- Write *your name* and *Index number* and *sign* in the spaces provided above.
- Answer *ALL* the questions in section *A* and *B* in the spaces provided in this booklet.
- Answer *any two* questions in section *C* in the spaces provided after the last question.

For Examiner's Use Only:

SECTION	QUESTIONS	MAXIMUM SCORE	CANDIDATES SCORE
A	1-14	30	
B	15-17	20	
C	18-20	40	
	TOTAL	90	

Answer all questions

1. State 3 ways of stimulating milk let down in a dairy cattle 3mks

.....

.....

.....

.....

2. State 3 systems of attack of Gumboro disease in poultry 3mks

.....

.....

.....

.....

3. Outline 2 difference between diesel engine and petrol engine 2mks

.....

.....

.....

.....

4. i Differentiate between maintenance ration and production ration 2mks

.....

.....

.....

.....

ii Define the term digestibility 1mk

.....

.....

5. Give 4 reasons for keeping rabbits in our farms 2mks

.....

.....

.....

.....

.....

.....

6. State 2 reasons for feeding bees

2mks

.....
.....
.....

7. Name 4 factors that predispose our livestock to diseases

2mks

.....
.....
.....

8. State 3 factors that determine the type of farm tools found in a poultry farm

3mks

.....
.....
.....

9. Name the final product of the following food component absorbed in the following

3mks

- i carbohydrate.....
- ii protein.....
- iii fats and oils.....

10. State 3 factors considered when sorting and grading eggs for the market

3mks

.....
.....
.....

11. Outline 3 general uses of solar energy in Agricultural sector

3mks

.....
.....
.....

12. List down 2 sources of water in the animal's body

1mk

.....
.....
.....

Answer all questions in this section

13. Diagram below illustrate some spanner used in our workshop

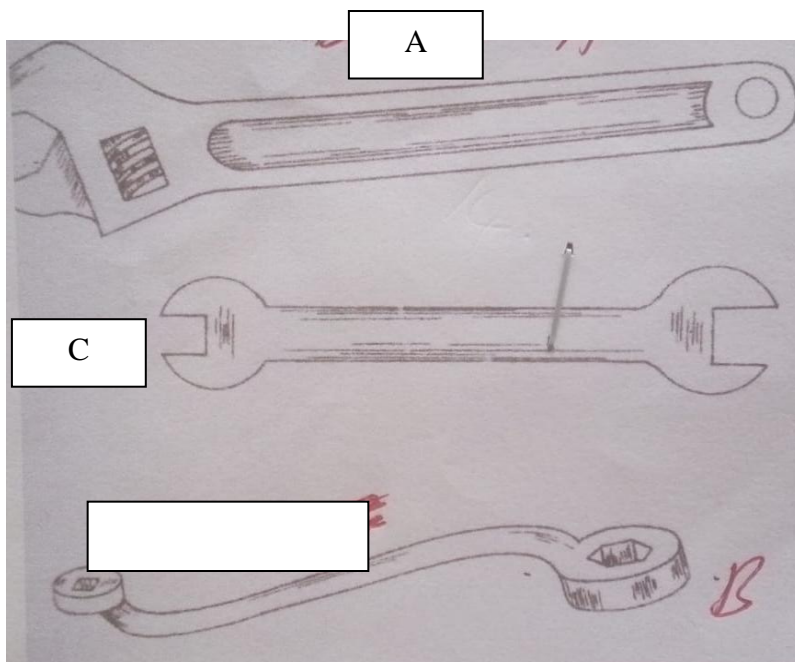

i) Identify diagram A, B and C 3mks

A.....
B.....
C.....

ii) State the functions of tool B and C 2mks

B.....
C.....

iii) Give one advantage of tool A over B and C above 1mk

.....
.....
.....

iv) List down two maintenance practices for tool A above 2mks

.....
.....
.....

14. Study the pictures below and answer the questions



i) Identify pictures labelled J, K and H

3mks

J.....
 K.....
 H.....

ii) State one duty of each bee labelled J, K and H above

3mks

J.....
 K.....
 H.....

iii) Name two parasites that attack bees

2mk

.....
.....

15. Study the practice used by the farmer below and answer the questions that follows.



i) Identify the method used by the farmer

1mk

.....
.....

ii) State three reasons why the practices is done in sheep

3mks

.....
.....
.....
.....
.....
.....

SECTION C:

40 MKS

Answer any 2 questions

16. a) Explain 5 factors that predispose lactating animals to mastitis 10mks

b) Explain 5 reasons for maintain livestock production tools and equipment 10mks

17 a) Explain 5 major characteristics of beef cattle breed 10mks

b) Explain 5 factors considered when siting a fish pond 10mks

18. a) Briefly discuss mechanical methods of controlling ticks in our farm 10mks

b) Explain 5 factors considered when selecting a breeding dairy goat 10mks

.....
.....



BUTERE GIRLS' NATIONAL SCHOOL MOCK EXAMS 2025



Kenya Certificate of Secondary Education

NAME _____ ADM NO _____ CLASS _____

231/1
BIOLOGY
PAPER 1
THEORY

TIME: 2 HOURS

Biology
Paper 1

INSTRUCTIONS TO CANDIDATES:

- Write your **name** and your **admission number** in the spaces provided above.
- **Sign** and **write** the date of the examination in the spaces provided above.
- Answer **all** the questions in the spaces provided.

For Examiner's Use Only:

QUESTIONS	MAXIMUM SCORE	CADNIDATE'S SCORE
1 – 27	80	

1. The diagram below shows part of the plant tissue.

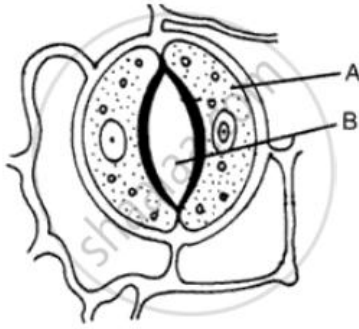

a) Name the cell labeled A, and part labeled B. (2 marks)

A.....

B.....

b) State two adaptations of cell labeled A to its function. (2 marks)

.....
.....
.....
.....

2. state three adaptations of the Spermatozoon to its function (3marks)

.....
.....
.....
.....

3. Explain the significance of the flow system in the nephron where the glomerular filtrate flows in opposite direction to that of blood in the surrounding capillaries (2marks)

.....
.....
.....

(b) Name the hormone that controls:- (2marks)

(i) The percentage of water in blood

.....

(ii) The amount of salts in the blood

.....

4. Explain how the red blood cells of mammals are adapted for efficient transport of oxygen. (2marks)

.....

5. Identify the organelle shown below

(1mark)

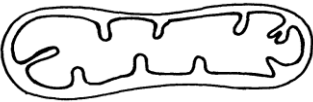

.....

(b) How is the organelle you have identified in (a) above suited to its function

(2marks)

.....

6. Name support tissues in plants characterized by the following

(2marks)

(i) Cells being turgid

.....

(ii) Cells being thickened by cellulose:

.....

7. Explain the biological disadvantage of growing some aesthetic plants in the living rooms.

(2marks)

.....
.....
.....
.....

8. A certain animal was found to have the following number of teeth on the upper jaw: - six molars, six pre molars, no canines and incisors; and on the lower jaw: - six incisors, two canines, six pre molars and six molars.

i) Write the dental formula of the above animal.

(2 marks)

.....
.....

ii) What is the likely diet of the animal?

(1mark)

.....

9. Briefly explain how bee stings cause swelling that can lead to death.

(3 marks)

.....
.....
.....
.....

10. Give an example of a phylum where all members have

(2marks)

(i) Open circulatory

.....

ii) Closed circulatory system

.....

b) Give the advantage of the closed circulatory system over the open circulatory system (1mark)

.....
.....

11. The table below shows the percentage of gases in samples of inhaled and exhaled air

Percentage in Gas	Inhaled air	Exhaled air
Oxygen	20.55	16.01
Carbon(iv) oxide	0.04	3.99
Nitrogen	78.53	75.20
Water vapour	0.48	4.42
Other gases	0.40	0.38

a) Use the information in the table to explain why the percentage of nitrogen is lower in exhaled air than in the inhaled air. (1mark)

.....

b) Account for:

(i) Percentage of water vapour in exhaled and inhaled air. (2marks)

.....
.....

(ii) Percentage of carbon (IV) oxide in the inhaled and exhaled air (1mark)

.....
.....

12. Give a reason why fats are respired less often in the human body yet they yield higher amounts of energy per unit weight than carbohydrates. (2marks)

.....
.....
.....

13. Name two parts in the kidney nephron where re-absorption of water takes place. (2 marks)

.....
.....

14. Explain the role of the following parts of the mammalian skin (3mks)

(i) Malphigian layer:

.....
.....
.....

(ii) Sebaceous gland:

15. The diagram below shows how blood glucose in mammalian body is regulated.

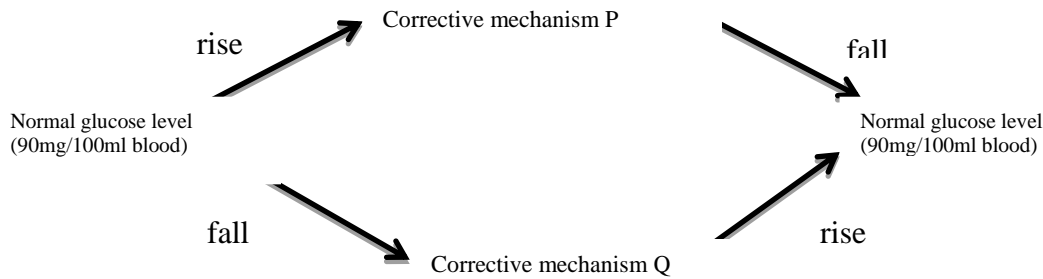

a) Explain what happens during corrective mechanism P (3marks)

.....

.....

.....

.....

(b) Name the hormone involved in corrective mechanism Q (1mark)

.....

16. State two characteristics found only in phylum Chordata (2 marks)

.....

.....

17. Diagram below shows a stem of a plant growing round a tree trunk.



(a) Explain how the process is occurs. (3marks)

.....

.....

.....

.....

(b) State the significance of the process above. (1mark)

.....

18. A horse has 64 chromosomes in its somatic cells while a donkey had 62. A mule is produced when a horse mates with a donkey. However a mule is sterile.

a) Work out the number of chromosomes in a mule. (1mark)

b) Why is the mule sterile? (2marks)

19. Moulting is shedding of the exoskeleton of arthropods such as cockroach to allow for growth.

(a) Name the hormone that leads to the formation of the cuticle in larval stage. (1 mark)

(b) Sketch the life cycle of the cockroach. (3 marks)

20. Explain how the mammalian eye performs each of the following:-

(i) Focusing far objects. (2marks)

(ii) Adjustment of the amount of light entering the eye in dim light conditions. (2marks)

21. The diagram below shows a joint in a mammal. Study it and answer the questions.

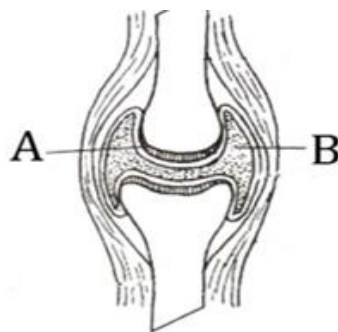

(a) State the functions of parts A and B (2marks)

A.....

B.....

(b) Name the type of joint illustrated by the diagram (1mark)

.....

(c) State one adaptation of joint named in (b) above (1mark)

.....

22. The photograph below illustrates a common fresh lake inhabiting organism. Study it and answer the following questions.



a) Name the habitat of the organism (1mark)

.....

b) Name the class to which the organism belong (1mark)

.....

c) Name two characteristic of living things shown in the above photograph (2marks)

.....

.....

23. During a lesson, students observed the structure of bat, cat and human forelimbs to determine their evolutionary relationship.

a.) State the name given to the structure of the limbs observed by the students. (1mark)

.....

b.) Name the type of evolution illustrated by the structure of the limbs observed. (1mark)

.....

c) State the significance of the type of evolution illustrated by the limbs. (1mark)

.....

24. State one way in which plants get rid of the following metabolic wastes: (2marks)

a) Excess water:

.....

b) Caffeine:

.....

25. Explain why live specimens cannot be viewed using an electron microscope (2marks)

.....

.....

.....

26. Explain how smoking affects the amount of oxygen taken up by the blood (3marks)

.....

.....

.....

27. The diagram below illustrates an experiment to determine the rate of a certain process in a small insect.

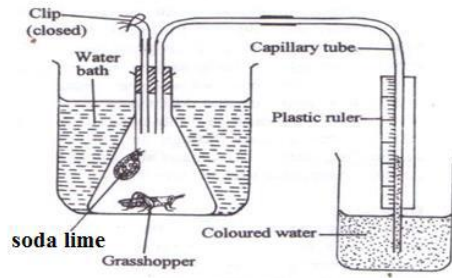

a) State the changes observed after the experiment has run for five minutes. (1 mark)

b) Why is it necessary to place the flask in a water bath? (1 mark)

c) Name and the significance of this process under investigation. (1 mark)



BUTERE GIRLS' NATIONAL SCHOOL

MOCK EXAMS 2025



Kenya Certificate of Secondary Education

NAME _____ ADM NO _____ CLASS _____

231/2
BIOLOGY
PAPER 2

TIME: 2 HOURS

Biology Paper 2

INSTRUCTIONS TO CANDIDATES:

- Write your **name** and **admission number** in the spaces provided.
- Sign and write the date of examination.
- This paper consists of **two** sections A and B.
- Answer **all** the questions in Section A in the spaces provided.
- In section B answer questions 6 (compulsory) and either question 7 or 8 in the spaces provided.
- Check and ascertain that no questions are missing.

For Examiner's Use Only:

SECTIONS	QUESTION	MAXIMUM SCORE	CANDIDATES SCORE
A	1	8	
	2	8	
	3	8	
	4	8	
	5	8	
B	6	20	
	7	20	
	8	20	
TOTAL SCORE		80	

SECTION A (40 MKS)

Answer ALL the questions in this section in the spaces provided on the question paper.

1. The diagram represents bones at joint in the hind limb of a mammal.

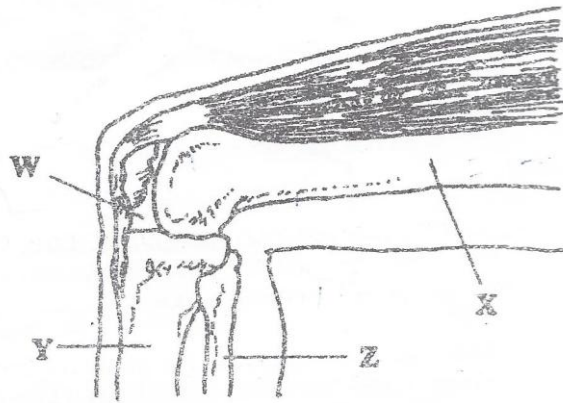

(i) Name the bones labeled (3mks)

X.....

Y.....

Z.....

(ii) a) name the substance found in the place labeled W (1mk)

.....

b) State the function of the substance named in (B) I above. (1mk)

.....

(iii) name the structures that joins the bones together at the joints (1mk)

.....

(iv) state the difference between ball and socket joints and the one illustrated in the diagram above (1mk)

.....

(v) name the structure at the elbow that performs the same function as patella (1mk)

.....

.....

2. The photograph below shows components of blood from a ruptured blood vessel. Study it and answer the questions that follow.



a) Suggest the identity of the above blood vessel if a lot of digested food substances were found dissolved in part T. (1mk)

.....

b) Identify cell U and suggest its function. (2mks)

.....
.....

c) i) name three types of antigens that are likely to be present on the surface of the membrane of cell V (3mks)

.....
.....
.....

ii) Where in the human body is cell V produced? (1mk)

.....

d) What role does structure W play in blood clotting? (1mk)

.....
.....

3. (a) During a lesson, students observed the structure of a bat and human forelimbs to determine their evolutionary relationship.

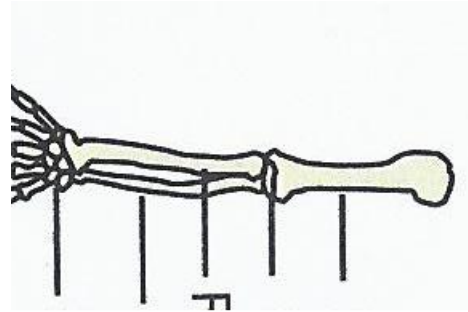
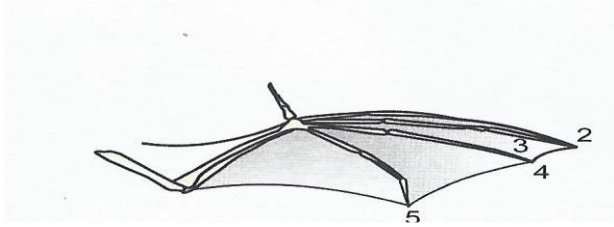

(i) State the term used to describe the structure of the limbs observed by the students. (1mk)

.....

(ii) Name the type of evolution illustrated by the structure of the limbs observed. (1mk)

.....

(iii) What evidence of evolution is illustrated by the limbs. (1mk)

.....

...

(iv) State the significance of the type of evolution illustrated by the limbs. (1mk)

.....

(b) Explain how comparative embryology is an evidence for organic evolution in vertebrates. (2mks)

.....

.....

.....

(c) Explain the theory of evolution by natural selection. (2mks)

.....

.....

.....

.....

4. In an experiment a group of students set up the test tubes as shown below

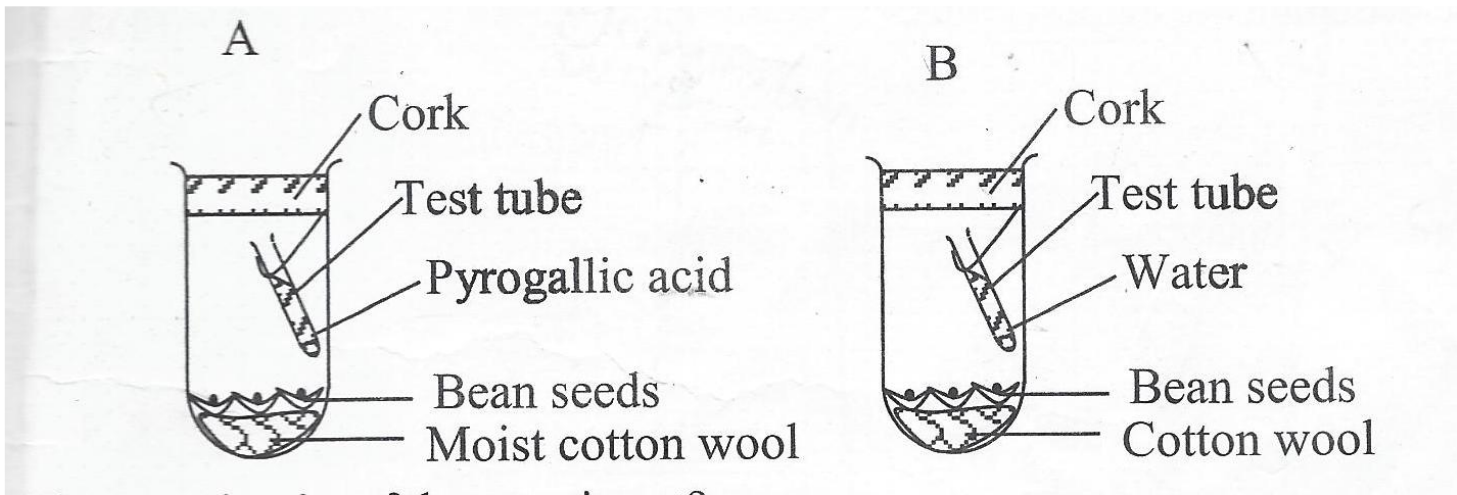

a) What was the aim of the experiment

(1mk)

.....

b) Why was pyrogallic acid included in the gas jar A

(1mk)

.....

c) What results would you expect in each of the gas jars A and B

(2mks)

A.....
 B.....

d) state two artificial ways of breaking seed dormancy

(2mks)

.....

e) Name two hormones that bring about rapid cell division in plants.

(2mks)

.....

5. Haemophilia is a genetic disease which is transmitted through a recessive gene linked to the X chromosome. The normal gene may be represented by H and the gene for haemophilia may be represented by h.

(a) A woman who is a carrier for haemophilia married a normal man. Work out the expected genotypic and phenotypic ratio of their children. (Show your working.) (6mks)

(b) Hemophilia is more common in men than in women. Explain? (2mks)

.....

.....

.....

.....

.....

.....

SECTION B(40 MKS)

Answer question 6 (Compulsory) and either question 7 or 8 in the spaces provided after question 8.

6. An experiment was carried out to investigate the effect of temperature on the rate of reaction catalyzed by salivary amylase. The pH was maintained and the results are shown in the table below

Temperature °C	5	10	20	25	30	35	38	45	50
Rate of reaction (Arbitrary units)	0.3	0.5	1.2	2.0	3.5	4.8	4.8	2.5	0.8

- (a) Using the same axes, draw a graph of rate of reaction against temperature (7 marks)

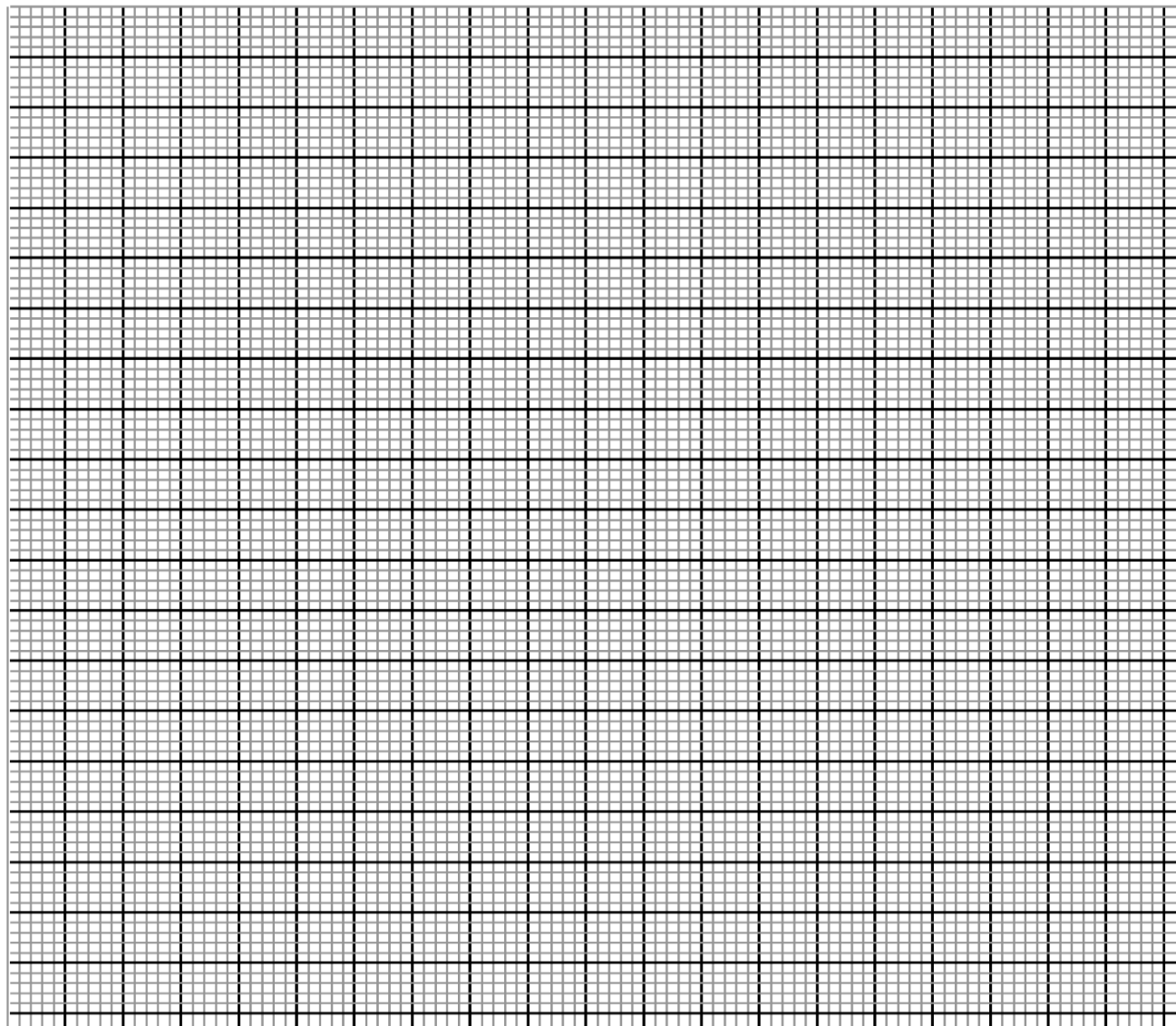

- b) What is the optimum temperature for this enzyme? (1mk)

.....

- c) At what temperature was the rate of reaction 1.4? (1mk)

.....

d) Account for the shape of the graph between:

i. 5°C and 35°C

(2mks)

.....
.....
.....
.....
.....

ii. 38°C and 50°C

(3mks)

.....
.....
.....
.....
.....

e) How is the hydrochloric acid from the stomach neutralized and where does this neutralization occur?(2mks)

.....
.....
.....
.....

f) Name one digestive enzyme in humans that works best in acidic conditions.

(1mk)

.....

g) State two factors that cause enzyme denaturation

(2mks)

.....
.....
.....

h) Name two factors that determine the amount of energy a human being requires in a day

(2mks)

.....
.....

7. a) Describe the role of each of the following hormones in human menstrual cycle.

a. Oestrogen.

(2mks)

ii. Progesterone

(3mks)

iii. Lutenising hormone

(3mks)

iv. Follicle stimulating hormone

(2mks)



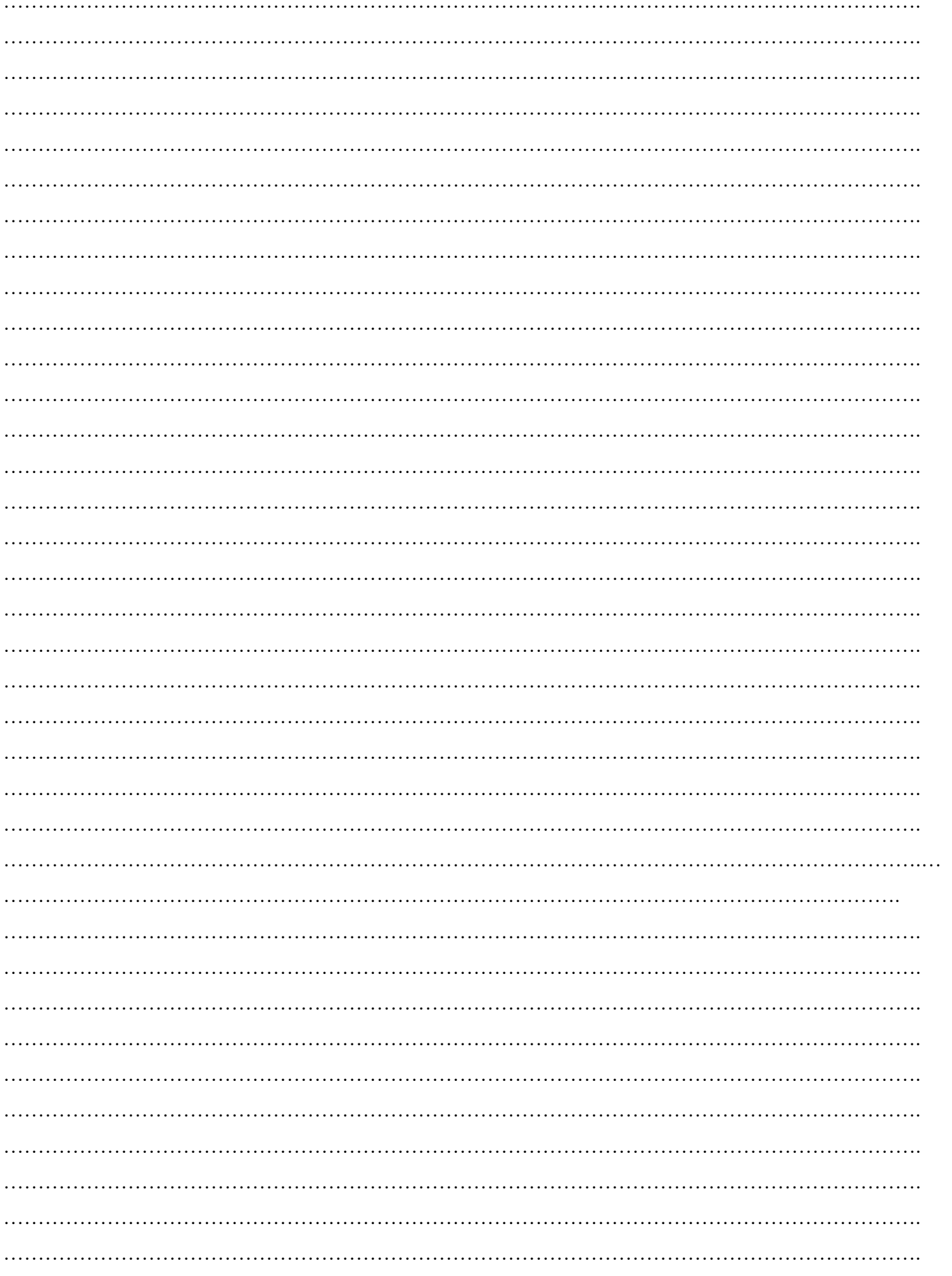



BUTERE GIRLS' NATIONAL SCHOOL MOCK EXAMS 2025



Kenya Certificate of Secondary Education

NAME _____ ADM NO _____ CLASS _____

231/3
BIOLOGY
PAPER 3

TIME: 1 $\frac{3}{4}$ HOURS

Biology Practical

INSTRUCTIONS TO CANDIDATES:

- Write your **name** and **admission number** in the spaces provided.
- Sign and write **date** of examination in the spaces provided above
- Answer **all** the questions in section **A** and **B**
- You are required to spend the first 15 minutes of the 1 $\frac{3}{4}$ hours allowed for this paper reading the whole paper carefully.

QUESTIONS	MAXIMUM SCORE	CANDIDATE'S SCORE
1		
2		
3		
TOTAL	40	

1. You are provided with solution **V** and substance **K**,
 2M hydrochloric acid,
 Thermometer,
 White tile
 Dropper,
 Measuring cylinder
 Three labels
 Six test tubes

a) Place a drop of solution **V** onto a white tile, add a drop of iodine solution and record your observation (1mark)

.....

b) Add 2ml of solution **V** in a test tube add equal amount of benedicts solution and heat record your observation (1mark)

.....

- c) Label three test tube as **A, B** and **C**. add 2ml of substance **K** in each of the labeled test tube,
 - In test tube **A** add 1ml of solution **V**, and place it in a water bath maintained at 37⁰c for 25 minutes.
 - In test tube **B** add 1ml of water and heat to boil for two minutes, allow it to cool for 1minute and add solution **V** Place it in a water bath maintained at 37⁰ c for 25minutes.
 - In test tube **C** add 1ml 2M hydrochloric acid and shake allow it to stand for 1minute, and add solution and place it in a water bath maintained at 37⁰c for 25 minutes.

- d) Cool the content in the test tube **A, B** and **C** by dipping in cold water in a beaker.
 e) Place 2ml of the content of **A** in a test tube and add equal amount of Benedicts' solution and record your observation in the table below. repeat the procedure using the content in test tube **B** and **C** (3marks)

Test tube A	
Test tube B	
Test tube C	

f) Account for your observation in the :-

Test tube **A**

(2marks)

.....

.....

.....

Test tube **B**

(2marks)

.....

.....

.....

Test tube **C**

(2marks)

.....

.....

.....

g) Name the likely identity of substance **K**

(1mark)

.....

h) What happens to the product in test tube **A** in the body of an organism

(2marks)

.....

.....

.....

2. Below are photographs of seedlings **G** and **X**

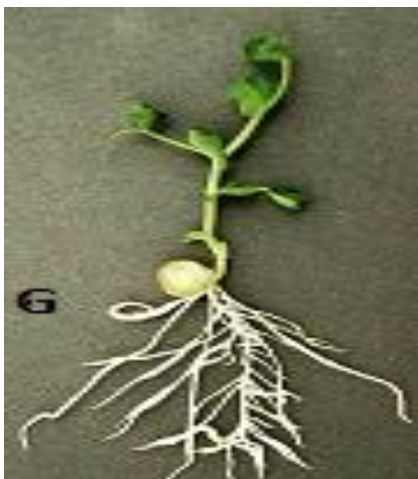

a) The two plants belong to the same class. with reason identify the class using observable features

(2marks)

Class

.....

Reason

.....
.....
.....

b) With a reason name the type of germination (4marks)

Type of germination in **G**

.....

Reason

.....
.....
.....

Type of germination in **X**

.....

Reason

.....
.....
.....

c) Give three functions of part labeled **B**. (3marks)

.....
.....
.....
.....

d) Explain how the part labeled **A** straightens (3marks)

.....
.....
.....
.....
.....

e) Name the type of root system that develops in seedling **G** (1mark)

.....

3. Use the photographs below and specimen **M** provided.



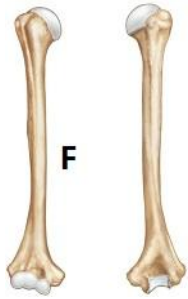

a) Identify bone :- (3marks)

M

.....

R

.....

F

.....

b) Name the type of skeleton formed by the above bones and specimen **M** (1mark)

.....

c) Name the type of joint formed at point **H** (1mark)

.....

d) Name the fluid found at point H and state it function (2marks)

Fluid

.....

Function

.....

.....

e) Give two adaptation of bone **F** to the formation of joint. (2 marks)

.....

.....

.....

.....

f) Name the substance that harden bones (1mark)

.....

g) Which type of connective tissue helps to stabilize the ankle joint during the movements? (1mark)

.....

h) Name the blood cells produced and the section on the bone that produces these blood cells

(2marks)

Blood cell

.....

Section of the bone

.....

i) Name the condition shown by the photograph below

(1 mark)



.....



BUTERE GIRLS' NATIONAL SCHOOL

MOCK EXAMS 2025



Kenya Certificate of Secondary Education

NAME _____ ADM NO _____ CLASS _____

565/1
BUSINESS STUDIES
PAPER 1

TIME: 2 HOURS

Business Studies
Paper 1

INSTRUCTIONS TO CANDIDATES:

- Write your name and Admission Number in the spaces provided.
- Answer *all* the questions in the spaces provided.

For Examiner's Use Only:

Question	Maximum score	Candidate's score
1-25	100 MARKS	

1. Outline four characteristics of underdevelopment. 4mks

- a)
- b)
- c)
- d)

2. Indicate the term described by the following statements. 4mks

- a) Inability of a business to meet its financial obligations.....
- b) Selling of new shares in the public market.....
- c) Value of a share as stated in the memorandum of association.....
- d) A middleman between the investigating public and the stock exchange.....

3. State any four functions of the central bank to the commercial banks 4mks

- a)
- b)
- c)
- d)

4. Outline four ways that can be used by an organization to protect its properties and control their use.

4mks

- a)
- b)
- c)
- d)

5. Highlight four roles played by broker in the channel of distribution 4mks

- a)
- b)
- c)
- d)

6. State four reasons why government licenses business people 4mks

- a)
- b)
- c)
- d)

7. State the principle of insurance to which each of the statement relates. 4mks
- a) There is a close connection between causes of loss and actual risk for compensation to be effected
.....
 - b) A person can only insure such properties whose destruction would result in financial loss to him or her.....
 - c) Compensation is paid only up to the amount of real loss.....
 - d) The insurer stakes over the residual of the property from the insured to the insurer.....

8. The inflation levels vary from one country to another. State any 4 levels that can be experienced in different economies of the world. 4mks
- a)
 - b)
 - c)
 - d)

9. Outline four characteristics of a monopoly market structure 4mks
- a)
 - b)
 - c)
 - d)

10. The following balances were extracted from the books of Kwetu Traders for the month ended on 31st March 2025.

	SH.
Sales	420,000
Purchases	240,000
Motorvan	300,000
Equipment	120,000
Debtors	80,000
Creditors	40,000
Expenses	160,000
Capital	440,000

Prepare trial balance of Kwetu Traders for the month ended 31st March 2025.

11. Give four reasons why the government inspects goods in bonded warehouses. 4mks

- a)
- b)
- c)
- d)

12. State four reasons that lead to termination of an insurance policy. 4mks

- a)
- b)
- c)
- d)

13. Indicate the type of utility created by each of the following activity 4mks

Activity	Type of utility
a) Milling wheat grain into flour	
b) Transporting wheat grain	
c) Selling bread in a shop	
d) Storing grain in silos	

14. State four factors that a firm should consider when deciding on goods to produce 4mks

- a)
- b)
- c)
- d)

15. Outline four circumstances under which a proforma invoice may be used. 4mks

- a)
- b)
- c)
- d)

16. Indicate for each of the following transactions in the table below the source document from which the transaction would be recorded. 4mks

Transaction	Source document
a) Sale of goods on credit	
b) Correction of an undercharge	
c) Goods returned	
d) Purchases on credit	

17. Outline four characteristic of a country that suffers from inflation. 4mks

- a)
- b)
- c)
- d)

18. Outline four features of liners in sea transport 4mks

- a)
- b)
- c)
- d)

19. A business can improve its internal environment. State 4 ways in which it can be improved 4mks

- a)
- b)
- c)
- d)

20. Highlight four factors that may influence an individual's demand for money in order to fulfil the transaction Motive. 4mks

- a)
- b)
- c)
- d)

21. Umoja Traders had the following assets and liabilities on 1st January 2024.

	SH.
Motor vehicle	400,000
Debtors	360,000
Bank	16,500
Stock	52,000
Bank loan	38,550

For the year ended 31st December 2024 the following information was available

- i. Additional capital sh.5,000
- ii. Drawings: cash sh.20,000 stock sh.15,000
- iii. Net loss sh.68,480

Calculate capital on 31st December 2024. 4mks

22. Outline four qualities of a good sales person 4mks

- a)
- b)
- c)
- d)

23. Fill in the spaces in the table below

4mks

Fixed asset (FA)	Current asset (CA)	Long term liabilities (LTL)	Short term liabilities (STL)	Capital
a) 130,000	70,000	40,000	25,000	
b)	610,000	130,000	115,000	425,000
c) 160,000	215,000		65,000	100,000
d) 1,105,900		550,000	175,400	830,500

24. Outline four circumstances under which a country may control imports.

4mks

- a)
- b)
- c)
- d)

25. The following information relates to Kimwa Traders for the year ended 30th September 2009.

	SH.
Sales	150,000
Opening stock	25,000
Purchases	130,000
Mark up	25%

Prepare a trading account for the year ended 30th September 2009



BUTERE GIRLS' NATIONAL SCHOOL

MOCK EXAMS 2025



Kenya Certificate of Secondary Education

NAME _____ ADM NO _____ CLASS _____

NAME _____ ADM NO _____ CLASS _____

565/2

PAPER 2

BUSINESS STUDIES

TIME: 2 ½ HOURS

Business Studies Paper 2

INSTRUCTIONS TO CANDIDATES:

- *This paper consists of six questions*
- *Answer any **five** questions in the answer booklet provided.*
- *All questions carry equal marks*

1. a) Explain 5 ways in which the government supports entrepreneurship activities. 10mks
 b) Explain 5 advantages of being a member of economic block such as the East African Community to a country like Kenya. 10mks
2. a) Explain 5 methods that can be used to improve sales promotion of products. 10mks
 b) The following information relates to Wambui Traders for the year ended 31/12/2024

Turnover/sales	sh.270, 000
Margin	40%
Rate of stock turnover	6 times
Expenses	40,000

Calculate:

 - i) Gross profit 3mks
 - ii) Cost of sales 2mks
 - iii) Net profit 1mk
 - iv) Average stock 2mks
 - v) Mark up 2mks
3. a) Outline 5 characteristics of a good development plan in a country. 10mks
 b) Discuss 5 benefit of division of labour to an organisation. 10mks
4. a) Explain 5 ways in which the government may increase the demand of a commodity. 10mks
 b) Discuss 5 challenges one would face when measuring national income using expenditure approach. 10mks
5. a) Explain 5 advantages of written communication. 10mks
 b) Explain 5 principles of an efficient tax system. 10mks
6. a) Kenya is a developing economy with a target of full industrialization by 2030 but with an increase in the number of unemployed youths. Discuss 5 causes to this. 10mks

The trial balance of Wamunyo Traders as at 1st June 2024 is given below.

	Dr	Cr
Stock	76,500	
Creditors		450,400
Debtors	350,000	
Bank	260,400	
Fixed assets	970,200	
Cash	120,500	
Capital		1,300,000
Lighting due	<u> </u>	<u>27,200</u>
	<u>1,777,600</u>	<u>1,777,600</u>

During the month the following transactions took place in 2024 June.

- 5th June 2024 paid a creditor sh.228, 000 by cheque in full settlement of a debt after 5% cash discount.
- 15th June 2024 withdrew sh.100, 000 from bank for office use.
- 28th June 204 received sh.160, 000 cash from a debtor after allowing cash discount of sh.40, 000

Required: Record the above transactions in the relevant ledger account and balance them off. 10mks



BUTERE GIRLS' NATIONAL SCHOOL

MOCK EXAMS 2025



Kenya Certificate of Secondary Education

NAME _____ ADM NO _____ CLASS _____

233/1
CHEMISTRY
PAPER 1

TIME: 1 HOUR

**Chemistry
Paper 1**

INSTRUCTIONS TO THE CANDIDATES:

- Write your **name** and **Admission number** in the spaces provided.
- Answer **all** the questions in the spaces provided.
- Mathematical tables and electronic calculators may be used
- All working **MUST** be clearly shown where necessary.

For Examiner's Use Only:

Question	Maximum score	Candidate's score
1-25	80 MARKS	

1. The element Y has an electronic arrangement 2.8.2

i) Give the valency of the element. (1 mark)

.....

ii) What is the likely nature of its chloride? (1 mark)

.....

2. a) briefly explain the preparation of flower extract indicator. (2 marks)

.....

.....

b) State the observation when sodium hydroxide is added to sodium hydroxide solution. (1 mark)

.....

.....

3. A student set up an experiment as shown in the diagram below.

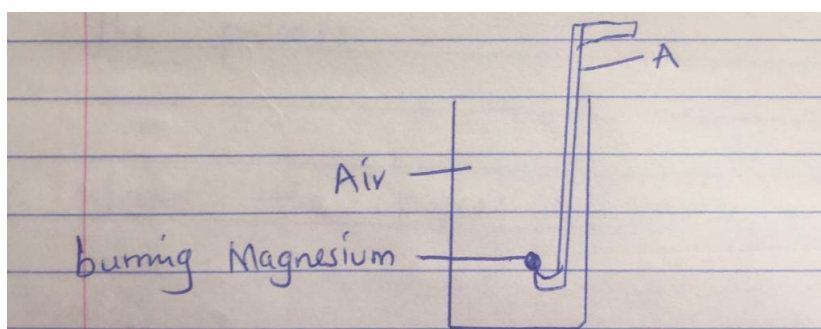

i) label the apparatus A (1 mark)

ii) Name the two compounds formed from the above experiment. (1 mark)

.....

.....

iii) Write the two equations showing the formation of the compounds in (ii) above. (2 marks)

.....

.....

4. An anhydrous salt Q (relative formula mass = 125) combines with water to form hydrated salt $Q \cdot XH_2O$. It is found that 50g of Q combine with 36g of water. Find the value of X (H = 1 O = 16) (3 marks)

5. The diagram below represents the extraction of sulphur by Frasch process.

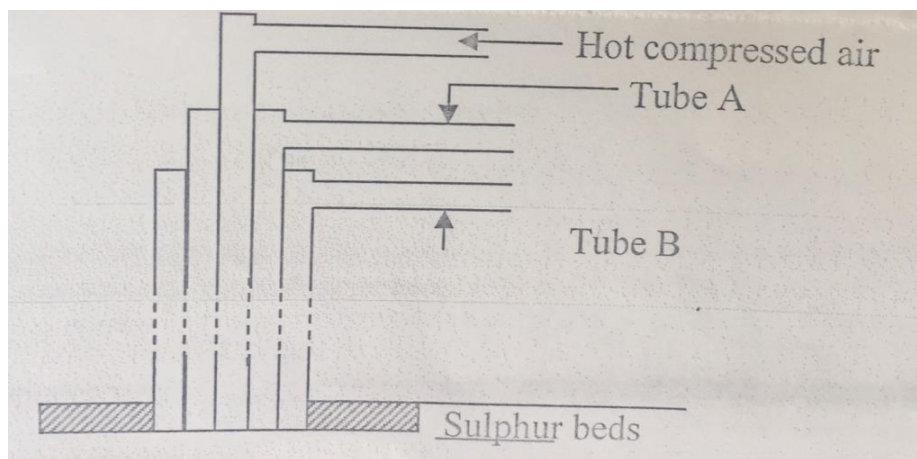

a) Name the substances that passes through. (2 marks)

A

B.....

b) What is the purpose of hot compressed air in the process? (1 mark)

.....

6. Name the process taking place in I, II and III below. (3 marks)



.....



.....



.....

7. State and explain the observation that would be made when zinc powder is heated with copper II oxide. (2 marks)

.....

.....

.....

8. An aqueous solution of hydrogen chloride gas reacts with manganese IV oxide to form chlorine gas while a solution of hydrogen chloride gas in methylbenzene does not react with manganese IV oxide. Explain. (2 marks)

.....

.....

.....

9. a) state Boyle's law. (1 mark)

.....

.....

b) A gas occupies 500cm³ at 27°C and 100000 pa. What will be its volume at 0°C and 101325 pa? (2 marks)

10. Given the equation below.



Identify the species that acts as:

i) A base. Explain. (2 marks)

.....
.....

ii) An acid. (1 mark)

.....
.....

11. a) define the standard heat of formation. (1 mark)

.....
.....

b) Draw energy cycle diagram to show how the standard heat of formation of ethanol (C₂H₅OH) can be determined from standard heats of combustion of its elements. (2 marks)

c) given that $\Delta H_f(\text{C}) = -393 \text{ kJ/mol}$ $\Delta H_c(\text{C}_2\text{H}_5\text{OH}) = -1368 \text{ kJ/mol}$. Calculate the enthalpy of formation of C₂H₅OH. (2 marks)

12. A steady current of 0.2 amperes was passed through molten silver bromide for 80 minutes.

a) Calculate the quantity of electricity that passed through the set up. (1 mark)

b) Calculate the mass of product deposited at the cathode (IF = 96500 C Ag = 108 Br = 80) (2 marks)

13. a cleansing agent L can be made using the scheme below.



i) Draw the structure of L. (1 mark)

ii) To which class of cleansing agents does it belong to? (1 mark)

.....

iii) State any advantage of L as a cleaning agent. (1 mark)

.....
.....

14. in an experiment involving the reaction between magnesium and 1M hydrochloric acid, the volume of hydrogen gas produced at various time intervals was measured. The experiment was repeated using the same amount of magnesium reacting with 2M hydrochloric acid. On the axis below sketch the expected results for the two experiments and label them. (2 marks)

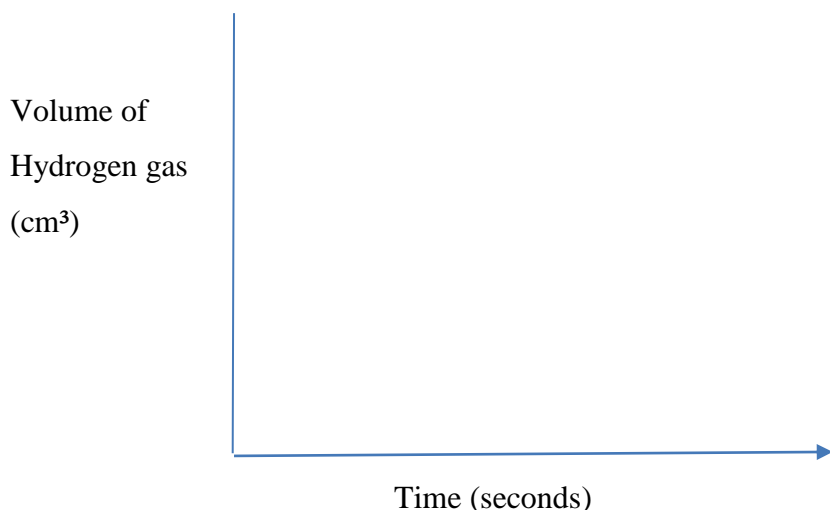

15. in an experiment to separate a mixture of two liquids A and B , a student setup the apparatus as shown below.

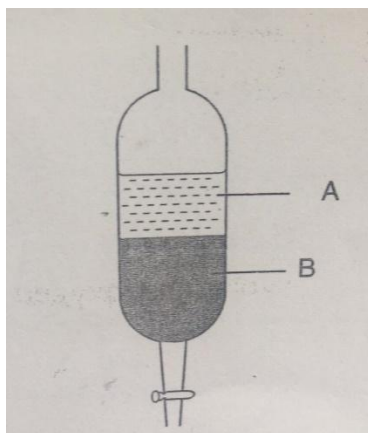

a) Name the apparatus. (1 mark)

.....

b) Which liquid is denser? (1 mark)

.....

c) Which other method can be used to separate the two liquids. (1 mark)

.....

16. a) define the term half-life. (1 mark)

.....

b) If a sample of cobalt has an activity of 1000 counts per minute, determine the time it would take for its activity to decrease to 62.50 if the half-life of the element is 30 minutes. (2 marks)

c) Complete the diagram below to show how alpha and beta particles from a radioactive source can be distinguished from each other. Label your diagram. (2 marks)

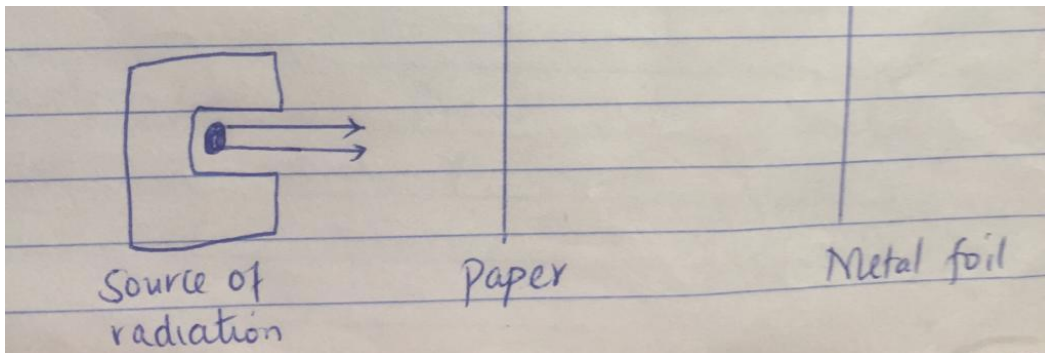

17. Lead II oxide reacts with acids and alkalis.

a) Write the equation for the reaction between lead II oxide and:

i) Dilute nitric V acid (1 mark)

.....

ii) Sodium hydroxide solution. (1 mark)

.....

b) What property of lead II oxide is shown by the reactions in (a) above. (1 mark)

.....

18. The diagram below represents a set up for the laboratory preparation of oxygen gas.

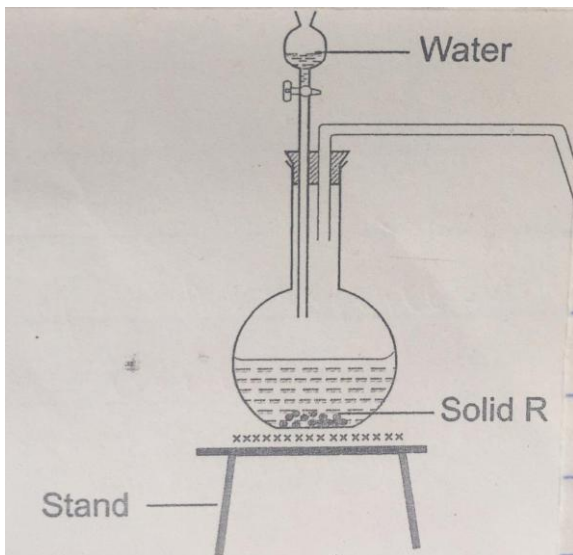

a) Complete the diagram for the collection of oxygen gas. (1 mark)

b) Name solid R. (1 mark)

c) Write the equation of the reaction in the above setup. (1 mark)

d) Give two industrial uses of oxygen gas. (1 mark)

19. The graph below shows the solubility curves for salts X and Y.

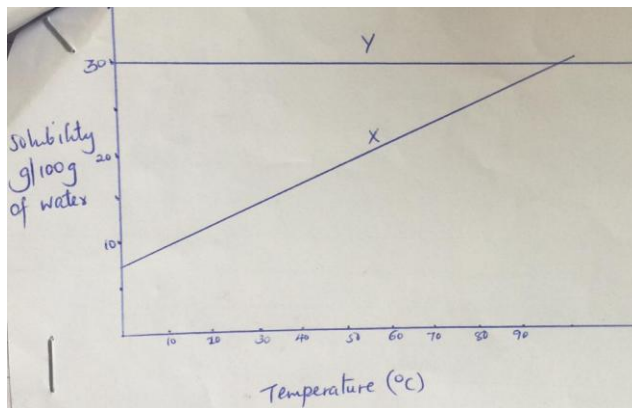

a) Which of the two salts is more soluble in water? Explain.

b) State and explain what happens when 100g of solution containing 20g of salt X and 20g of salt Y is cooled from 90°C to 20°C. (2 marks)

20.a) which of the following reactions will not produce carbon IV oxide?

i) Ammonium carbonate and hydrochloric acid.

ii) Heating sodium carbonate.

iii) Heating potassium hydrogen carbonate.

iv) Calcium carbonate and sulphuric VI acid. (1 mark)

c) Write equations for the reactions which liberate carbon IV oxide in (a) above. (2 marks)

21. Zinc metal and hydrochloric acid reacts to produce hydrogen gas.

a) Determine the reagent that was in excess given 1.96g of zinc metal were reacted with 100cm³ of 0.2M hydrochloric acid. (2 marks)

b) Calculate the total volume of hydrogen gas that was liberated at S.T.P in (A) above.

c) Calculate the total volume of hydrogen gas that was liberated at S.T.P in (a) above.

(Zn = 65.4 molar gas volume = 22.4 litres at STP) (2 marks)

22. Study the information in the table below and use it to answer the questions that follow.

Element	Electrical conductivity	Ductility	Action of water
A	Good	Good	No reaction
B	Good	Poor	No reaction
C	Good	Good	Reacts

Select an element with

a) Is likely to be in group II of the periodic table. (1 mark)

.....

b) Could be used to make electric cables. (1 mark)

c) Is likely to be graphite. (1 mark)

23. Calcium oxide can be used to dry ammonia gas.

a) Explain why calcium oxide is not used to dry hydrogen chloride gas. (2 marks)

b) Name one drying agent for hydrogen chloride gas. (1 mark)

24. Given the equation.



Explain what happens to the position of equilibrium when:

i) More hydrogen is introduced into the system. (1 mark)

ii) The pressure of the system is reduced. (1 mark)

iii) Temperature is raised. (1 mark)

25. Excess carbon(II) oxide was passed over a heated sample of an oxide.

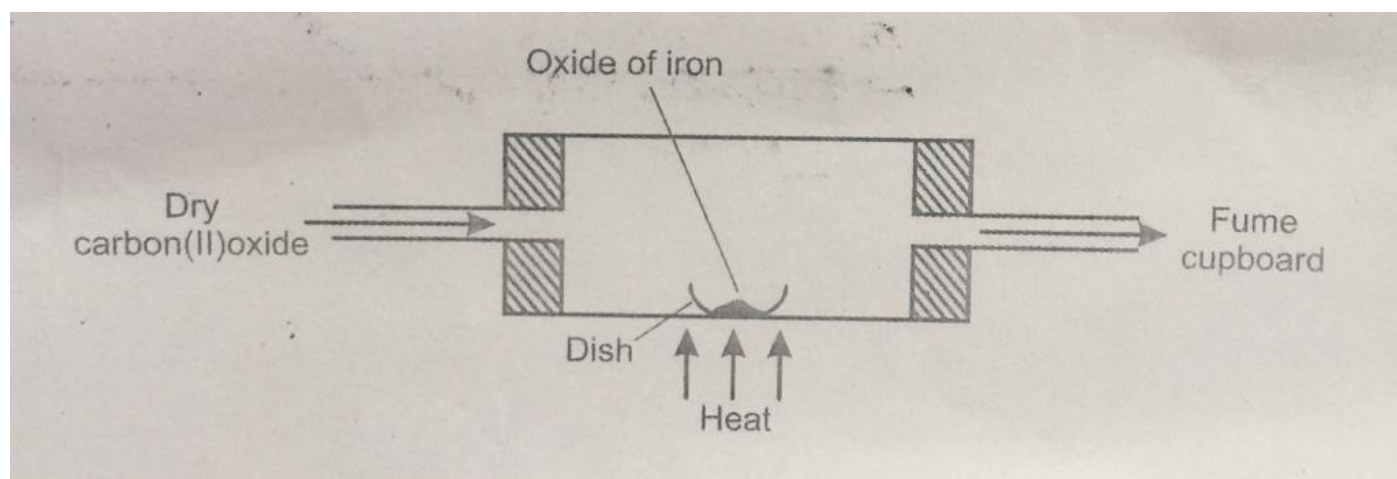

a) Write an equation for the reaction which took place in the dish. (1 mark)

b) Corrosion is a destructive process in which iron is converted into hydrated iron III oxide. State:

i) Two conditions necessary for rusting to occur. (1 mark)

.....
.....
ii) One method used to protect iron from rusting. (1 mark)

.....
.....
c) Explain why it is not advisable to wash iron tools using sea water. (1 mark)



BUTERE GIRLS' NATIONAL SCHOOL MOCK EXAMS 2025



Kenya Certificate of Secondary Education

NAME _____ ADM NO _____ CLASS _____

233/2

**CHEMISTRY
PAPER 2**

TIME: 2 HOURS

**Chemistry
Paper 2**

INSTRUCTIONS TO THE CANDIDATES:

- Write your **name** and **admission number** in the spaces provided above
- **Sign** and write the **date** of examination in the spaces provided.
- Answer **all** the questions in the spaces provided.
- All working **must** be clearly shown where necessary.
- Mathematical tables and electronic calculators can be used.

For Examiners Use Only

Question	Maximum score	Candidate's score
1	11	
2	9	
3	12	
4	13	
5	12	
6	12	
7	11	
Total	80	

1. Study the scheme below and answer the questions that follow.

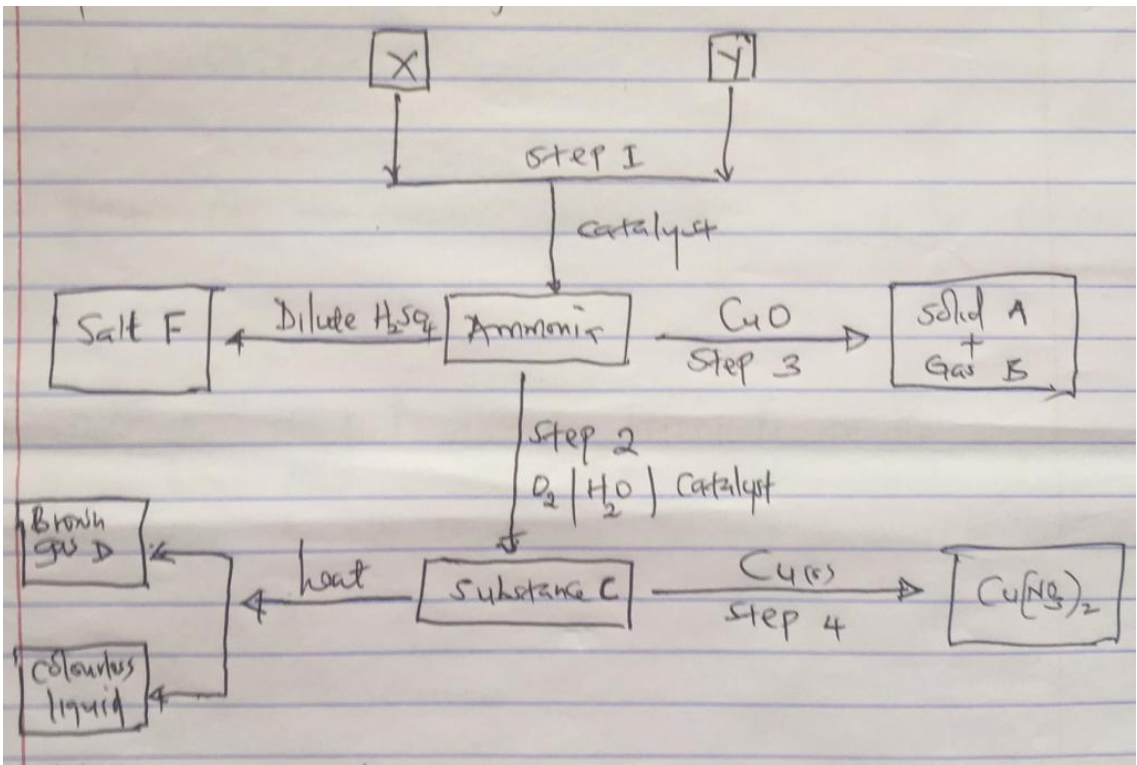

a) Identify X and Y. (2 marks)

i) X.....

ii) Y

b) Write a balanced chemical equation between X and Y (1 mark)

c) Name substances F, A, B and E (2 marks)

A.....

B.....

E.....

F.....

d) Write the chemical reaction for the formation of F (1 mark)

e) i) name the type of reaction that takes place between copper and ammonia. (1 mark)

ii) In the reaction in e (i) above, which species undergoes:

I: Reduction (1 mark)

II: Oxidation (1 mark)

f) State one economic use of substance F. (1 mark)

2. Study the standard electrode potentials for the elements given below and answer the questions that follow.

(The letters do not represent the actual symbols of elements.)

Elements	→	E°
$Q_{2(g)} + 2e^-$	→	$2Q^-_{(aq)} + 2.87v$
$R_{2(g)} + 2e^-$	→	$2R^-_{(aq)} + 1.36v$
$S^{2+}_{(aq)} +$	→	$S_{(g)} + 1.23v$
$2T^+_{(aq)} + 2e^-$	→	$T_{2(g)} + 0.00v$
$U^{2+} + 2e^-$	→	$U_{(s)} - 0.13v$
$V^{2+} + 2e^-$	→	$V_{(s)} - 0.76v$

a) i) what is the E° for the weakest reducing agent. (1 mark)

.....

ii) Which element is likely to be hydrogen? Give reason. (2 marks)

.....

.....

iii) Draw a diagram for the cell that would be obtained when elements of S and V are combined.

(3 marks)

.....

.....

.....

.....

.....

iv) Calculate the emf of the electrochemical cell in (iii) above.

.....

d) The diagram below represents the electrolysis of dilute sulphuric acid.

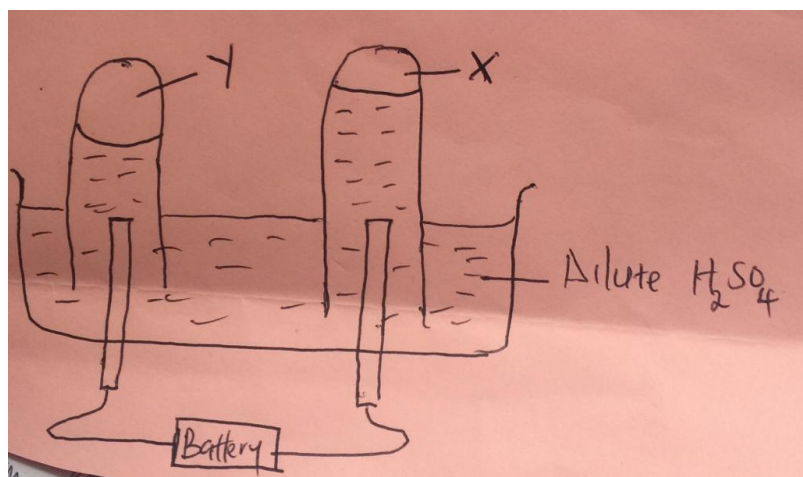

i) name gas X and Y.

(1 mark)

X.....

Y.....

ii) Write an equation for the formation of X.

(1 mark)

.....

iii) At what electrode does reduction takes place. Explain.

(2 marks)

.....

.....

.....

iv) Name the most suitable electrodes to be used in this experiment. Give reason. (2 marks)

electrode.....

Reason.....

a) other than location of the atom, state two differences between protons and electrons.

.....

.....

b) The grid below shows part of periodic table. Study it and answer the questions that follow.

			E	F			G	
	D						K	
H	J						L	M

b,ii) state the most reactive non-metal. Explain.

(2 marks)

.....

.....

ii) Identify an element that do not form compound. Explain.

(2 marks)

.....

.....

iii) Write down the formula of Nitride of D. (1 mark)

.....

iv) Briefly explain the following observations

I D has larger atomic radius than K. (1 mark)

.....

II E is better conductor than H. (1 mark)

.....

c) 1.08 g of element E was heated in a stream of excess chlorine gas

i) Write down the chemical equation for the reaction that occurred. (1 mark)

.....

ii) Calculate the mass of product formed (E=27, Cl = 35.5) . (2 marks)

.....

.....

.....

.....

d) Use dot (.) and cross (×) to draw a diagram between the following.

K and J. (2 marks)

F and G. (2 marks)

4. Aluminium is extracted using the electrolytic cell represented by diagram below.

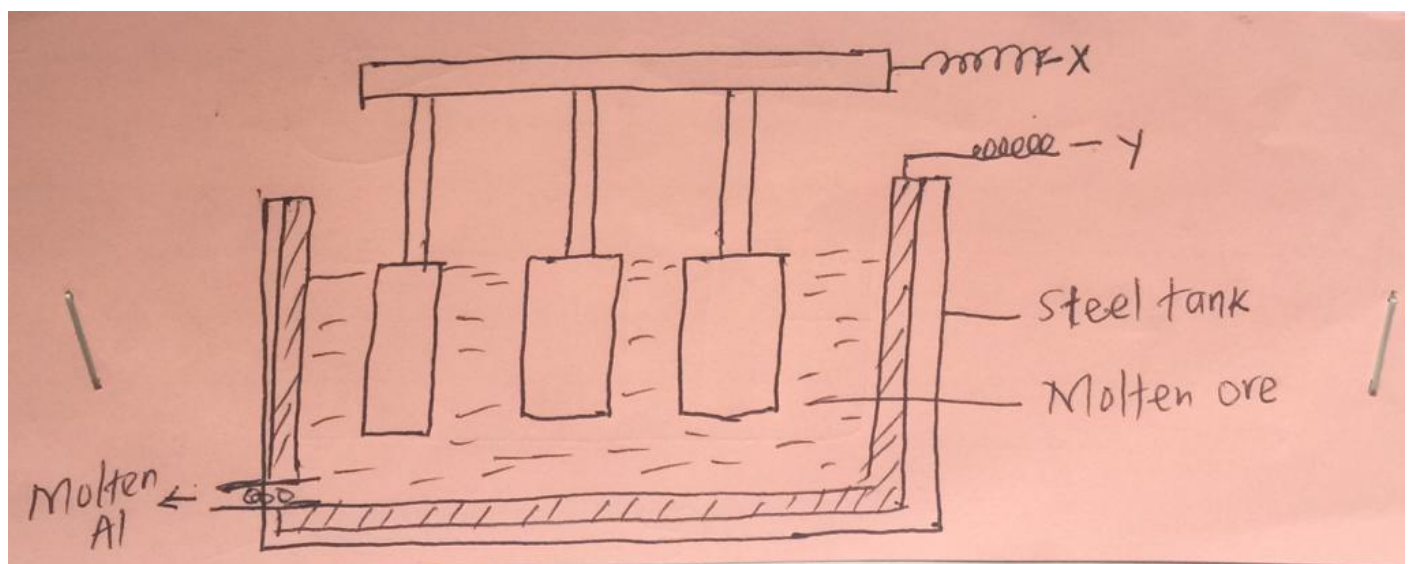

a) Why is aluminium extracted by electrolytic method? (1 mark)

.....
b) Name the electrodes labelled. (2 marks)

X.....

Y.....

b) i) The chief ore from which aluminium is extracted is bauxite.

.....
ii) Name two main impurities presented in the bauxite. (2 marks)

.....
.....
iii) Aluminium oxide is the main component in the bauxite with a melting point of 2015°C, but the electrolysis of molten aluminium oxide is carried at 800°C. Explain how this is achieved.

(2 marks)

.....
.....
.....
d) i) write the equation for the reaction taking place at anode. (1 mark)

.....
ii) one of the electrode is replaced periodically, which one and why? (2 marks)

.....
.....
e) During electrolysis of molten aluminium oxide a current of 88.0 amperes was passed through the cell for 8 hours. Calculate the mass of aluminium produced. (If = 96500, al = 27)

(3 marks)

.....
.....
.....
f) State two uses of aluminium. (1 mark)

.....
5. a) starting with zinc metal, describe how zinc carbonate can be prepared in the laboratory.

(3 marks)

.....
.....
.....
c) Three immiscible liquids X, Y and Z are such that X is less dens than Y and Z. Y is denser than Z. draw a well labelled diagram on how the 3 liquids can be separated effectively.

(3 marks)

c) When a carbonate of metal T was heated, solid P which turned yellow on cooling was formed.

i) Identify solid P (1 mark)

ii) Write a balanced chemical equation on the effect of heat on nitrate of silver. (1 mark)

d) Few drops of ammonium hydroxide were added to copper (II) sulphate solution.,

i) State the observation made. (1 mark)

ii) if excess of ammonium hydroxide is added to the resultant solution, state the observation and write the equation for the reaction that took place. (2 marks)

6. Study the flowchart below

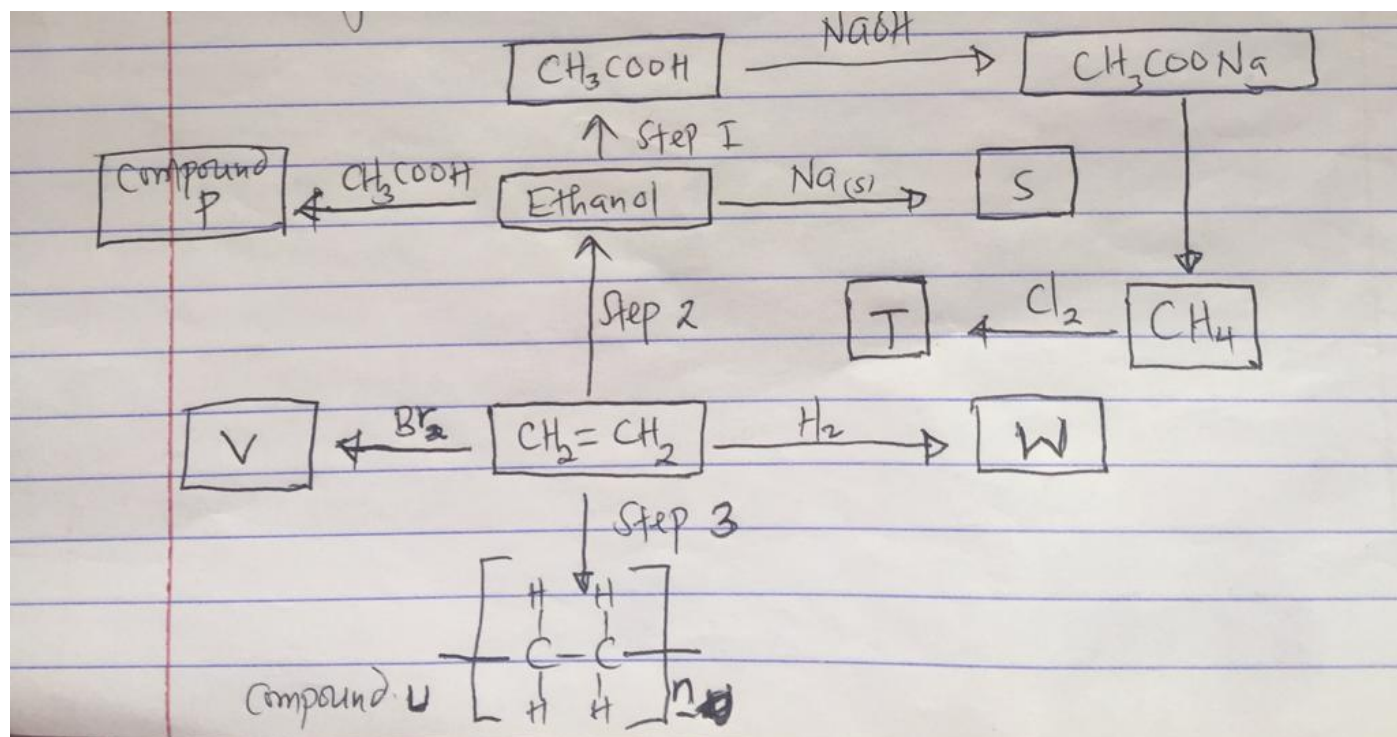

a) Write the name and formula of organic compounds V and W

i) Name of V (1 mark)

.....
Formula (1 mark)

.....
ii) Name of W (1 mark)

.....
Formula (1 mark)

.....
b) i) give the name of the process that leads to formation of P. (1 mark)

.....
ii) Give the conditions necessary for the formation of compound P. (1 mark)

.....
d) If the molecular mass of compound V is 8400, determine the value of n (C =12, H = 1) (2 marks)

.....
d) Write an equation that leads to formation of substance S. (1 mark)

.....
e) State and explain the observations made when substance W and C₂H₄ burns in excess air. (2 marks)

.....
7. The set up below was used to prepare dry hydrogen gas.

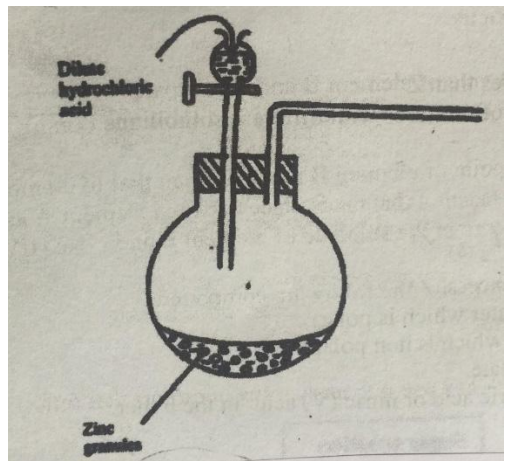

a.i) complete the diagram to show how a sample of dry hydrogen can be collected. (2 marks)
.....
.....

ii) Hydrogen gas is used in hardening of oil to fat in the manufacture of margarine. Give two other uses of hydrogen gas. (2 marks)

.....
.....

iii) Give reason why magnesium is not preferred in preparation of hydrogen gas. (1 mark)

.....

b) Write the formula of the substance added in preparation of hydrogen gas to speed up the reaction (1 mark)

.....

c) Describe a simple test for hydrogen gas. (1 mark)

.....



BUTEREGIRLS' NATIONALSCHOOL MOCK EXAMS 2025



Kenya Certificate of Secondary Education

Name: Index No:

School: Candidate's Signature:

Date:

Kenya Certificate of Secondary Education

233/3

CHEMISTRY

Paper 3

PRACTICAL

Time: 2 hours 15 Minutes

Instructions to Candidates

- ❖ Write your name and Adm no in the spaces provided above.
- ❖ Answer **ALL** the questions in the spaces provided in the question paper.
- ❖ **ALL** working **MUST** be clearly shown where necessary.
- ❖ Mathematical tables and silent electronic calculators may be used.
- ❖ Candidates should check the paper to ascertain that all the pages are printed as indicated and that no questions are missing.

FOR EXAMINER'S USE ONLY:

Question	Maximum Score	Candidate's Score
1	21	
2	14	
3	13	
Total Score	40	

1. You are provided with:
- 0.0238 Moles (equivalent to 3g) of solid G
 - Solution H, 0.04M acidified potassium manganate (VII)

You are required to:

- I. Determine the enthalpy of solution of solid G
- II. The number of moles of water of crystallization in solid G

Procedure I:-

Using a measuring cylinder place 50cm³ of distilled water into a 100cm³ of beaker. Stir the water gently with a thermometer and take its temperature after every half-minute. Record the reading in table I below. At exactly two minutes, add all solid G to the water at once. Stir well and take the temperature of the mixture after every half minute up to the fourth minute. Record your results in table I. Keep the solutions for procedure II below:

Table I

(a)

Time (min)	0	½	1	1 ½	2	2 ½	3	3 ½	4
Temperature (°C)					X				

(4mks)

- (b) On the grid provided, plot a graph of time (x-axis) against temperature (3mk)

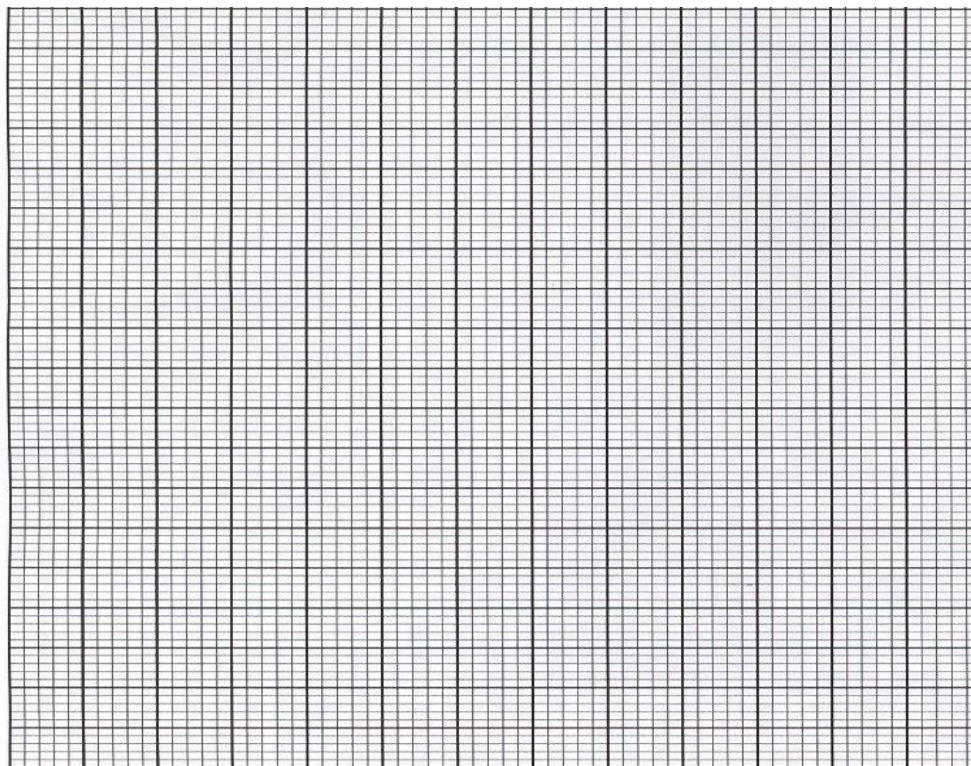

- (c) (i) On the graph, show the change in temperature ΔT (1mk)

(ii) To 2cm³ of solution, add both litmus papers .

Observations	Inferences
(1mk)	(1mk)

(iii) To 2cm³ of solution, add aqueous sodium hydroxide drop wise until excess.

Observations	Inferences
(1mk)	(1mk)

(iv) To 2cm³ of solution, add aqueous ammonia drop wise until in excess.

Observations	Inferences
(1mk)	(1mk)

(v) To 2cm³ of the solution, add 2 drops of aqueous potassium iodide.

Observations	Inferences
(1mk)	(1mk)

(vi) To 2cm³ of solution, add 3 drops of aqueous lead (ii)nitrate.

Observations	Inferences
(1mk)	(1mk)

(vii) To 2cm³ of solution, add 3 drops of aqueous Barium nitrate solution.

Observations	Inferences
(1mk)	(1mk)

3. You are provided with solid P. Carry out the test below. Write your observations and inferences in the spaces provided:-

(a) Place one third of solid P on a metallic spatula and burn it using a Bunsen burner.

Observations	Inferences
(1mk)	(½mk)

(b) Place the remaining of solid P in a test-tube . Add about 6cm³ of distilled water and shake.

(i) To 2cm³ of the mixture in (b) above add a spatula end full of NaHCO₃ solid.

Observations	Inferences
(1mk)	(½mk)

(ii) To 2cm³ of the mixture, add 2cm³ of acidified potassium dichromate (VI) and warm

Observations	Inferences
(1mk)	(1mk)



BUTERE GIRLS' NATIONAL SCHOOL

MOCK EXAMS 2025



Kenya Certificate of Secondary Education

NAME _____ ADM NO _____ CLASS _____

COMPUTER STUDIES

451/1

Paper 1

TIME: 2 ½ HOURS

Instruction to candidates

- Write your name and index number in the space provided above.
- Sign and write the date of examination in the spaces provided above.
- This paper consists of **two** sections **A** and **B**.
- Answer **all** the questions in section **A**.
- Answer question **16** (Compulsory) and any other **three** questions from section **B**.
- All answers should be written in the space provided in the question paper.
- Candidates should check the question paper to ascertain that all the pages are printed as indicated and that no questions are missing.

For Examiner's Use Only

Section	Question Number	Candidate's Score
A	1-15	
B	16	
	17	
	18	
	19	
	20	
Total Score		

SECTION A

(Answer all questions in this section)

1. Other than cost and compatibility, state **two** factors to consider when selecting an input device for an organization. (2 marks)

2. State the importance of the cache memory to the computer. (1 mark)

3. Distinguish between the address bus and the control bus in the CPU. (2 marks)

4. State any **two** disadvantages of printing documents using thermal printers. (2 marks)

5. State **one** advantage of storing data on an optical disk over the magnetic disk. (1 mark)

6. a. Define the term network topology. (1 mark)

- b. Distinguish between a logical and physical topology (2 marks)

7. a. Distinguish between a web portal and a blog. (2 marks)

b. List **four** components of an e-mail. (2 marks)

8. The tables below were extracted from Vincent’s Enterprise database. Use them to answer the questions that follows.

CUSTOMER TABLE				
CUSTOMER ID	ID NUMBER	NAME	ADDRESS	TOWN

ORDER TABLE					
ORDER ID	CUSTOMER ID	ORDER DATE	PARTICULARS	QUANTITY	UNIT COST

a. Identify the most appropriate primary keys in both tables. (1 mark)

b. Identify a candidate key in any of the tables. (1 mark)

c. Describe the relationship formed between the two tables. (1 mark)

d. Write a function that would be used in a query to display the delivery date; given that all deliveries are made three days after the order date. Name the query field “Delivery Date” (2 marks)

9. Explain **two** circumstances that may lead to use of crop tool in a word processing document. (2 marks)

10. State **two** advantages of using templates when creating documents in word processing. (2marks)

11. The emergence of Gen-Z popular ‘maandamano’ has led to many organizations in major cities in Kenya to embrace teleworking approach.

a) State the meaning of the term teleworking. (1 mark)

b) State **two** benefits that organizations gain by using this approach. (2 marks)

12. (a) (i) State the meaning of each of the following terms used in spreadsheets. (2 marks)

Value

Chart

(ii) A certain formula was typed in a cell within a worksheet. Upon execution the cell displayed the error #NULL. State the meaning of the error. (1 mark)

13. State **one** hardware technological difference between the second generation and the third generation computers. (2 marks)

14. State **three** ways of transforming a picture embedded in a Desktop Publishing application in order to fit in a designated space on a document. (3 marks)

b) State **two** application areas of a desktop publishing software. (2 marks)

15. List **two** duties performed by each of the following personnel. (3 marks)

i) System analyst

ii) Network administrator

iii) Computer trainer

c. Outline three methods used for testing and debugging a program. (3 marks)

17. An information system is a critical tool of success in any organization. For this reason, many organization set aside a lot of resources in supporting their information system.

a. Define the term information system. (2 marks)

b. Different methodologies are used to develop systems depending on the nature of the system and the organization.

i. Define the term **methodology** as used in systems development. (2 marks)

ii. State any **two** advantages of a prototype during system development. (2 marks)

iii. List any **four** tools that can be used to design a system. (2 marks)

iv. Identify the system flow chart symbol shown in the diagram below and state its function.



Symbol (1 mark)

Function (1 mark)

v. List the order in which the operating system organizes information from top to bottom. (2 marks)

vi. State the purpose of a disk diagnostic utility provided by the operating system. (1 mark)

vii. As John was booting his computer, the process was terminated before completion with an error message “Missing Operating System”, identify the reason for the error and its solution.

Reason (1 mark)

Solution (1 mark)

18 a) Mention **three** factors to consider when choosing a file organization method. (3 marks)

b) Define the term Data integrity.

(1 mark)

c) State **three** ways of minimizing threats to data integrity.

(3 marks)

d) Briefly describe the following data processing modes.

(3 marks)

i) Online processing.

ii) Real-time processing.

iii) Multi-programming

e) Linda does not understand why computers are said to be **Automatic** at the same time they have No Intelligent Quotient (IQ). Explain to her the observation concepts.

(2 marks)

f) Give **three** reasons to justify why many computer users today prefer saving their documents in the google drive.

(3 marks)

19. a) State **three** standard coding schemes used in computing. (3 marks)

b) Convert the following numbers.

i) 111.011_2 to decimal. (3 marks)

ii) 13.875_{10} to binary. (3 marks)

c) i) Give **three** reasons why most people prefer primary storage than secondary storage. (3 marks)

ii) A computer teacher put a rule that flash disks should not be used in the computer laboratory

a) Give a reason for the rule. (1 mark)

b) State **two** other alternatives that can be used to achieve the same objective. (2 marks)

20. The development of internet has succeeded in reducing the world into a global village.

a. State any **two** benefits of networking. (2 marks)

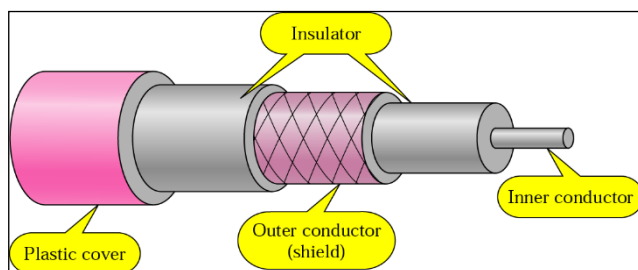

b. Identify the cable in the diagram below (1 mark)

c. State any **two** reasons for making it a better choice for a backbone in a bus topology network. (2 marks)

c. State **three** components of satellite communication.

(3 marks)

d. Distinguish between a switch and a router.

(2 marks)

e. Explain the following principles in relation to data integrity principle.

(2 marks)

i. Data integrity

ii Availability

f. John was promoted at work but James was not happy about it, he therefore decided to steal and destroy critical information from John's computer.

i. Identify the threat committed by James.

(1 mark)

ii. State two ways John could have avoided the threat mentioned in (i) above.

(2 marks)



BUTERE GIRLS' NATIONAL SCHOOL

MOCK EXAMS 2025



Kenya Certificate of Secondary Education

NAME _____ ADM NO _____ CLASS _____

COMPUTER STUDIES

PRACTICAL

Paper 2

TIME: 2 ½ HOURS

INSTRUCTIONS TO CANDIDATES

1. Type your name and admission number at the top right hand corner of each printout
2. Sign and write the date of the examination below the name and index number on each printout
3. Write your name and index number on the compact disks
4. Write the name and version of the software used for each question attempted in the answer sheet
5. Passwords should not be used while saving in the compact disks
6. Answer all the questions
7. All questions carry equal marks
8. All answers must be saved in your compact disks
9. Make a printout of the answers on the answer sheets provided
10. Hand in all the printouts and the compact disks.

QUESTION 1

- (a) (i) Create a folder and name it as the last three digits of your index number. (1 mark)
- (ii) Open a word processing program and type the following passage as it appears. Save as CENSUS in the folder created. (15 marks)

POPULATION CENSUS

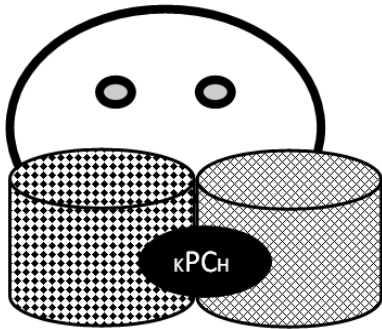

The total enumerated population was 47,564,296 Of which 23,548,056 were Males, 24,014,716 were Females.

1.1. Background Information

The first known population census in Kenya was conducted in ~~1897~~ and was basically a headcount. This was followed by the 1948 census that focused on non-natives. A complete census that enumerated ~~8.6 million~~ persons was conducted in 1962 and was used to set up political and administrative structures.

First post-independence census was undertaken in 1969 and enumerated ~~10.9 million~~ persons. Since then, the country has conducted decennial Population and Housing Censuses on a de-facto basis with the midnight of 24th & 25th August as the reference point.

1.2 Objectives of the 2019 Census

The specific objectives were to ascertain the following:

- | | | |
|---|---|---|
| <ul style="list-style-type: none">✓ Population size and spatial distribution;✓ Levels of fertility, mortality and migration;✓ Educational attainment; | <ul style="list-style-type: none">✓ Household composition;✓ Rate and pattern of urbanization;✓ Size and deployment of labour force; | <ul style="list-style-type: none">✓ Distribution of persons with disability;✓ Housing conditions✓ Agricultural indicators |
|---|---|---|

© 2019

- (a) Create a copy of the passage into a new blank document. (1 mark)
- (b) Save the document above as **Census 2** in the folder created. (1 mark)
- (c) Set the page as follows: (2 marks)
- (i) Margin : 1 inch all round
 - (ii) Paper size: A4
- (d) Spell check the document. (2 marks)
- (e) Perform each of the following on the document
- (i) Format the title **“Population census”** as follows: (3 marks)
 - (I) Font size: 36 pts
 - (II) Font style:algerian,
 - (III) italize and bold
 - (ii) Apply each of the following to the bulleted list: (2 marks)
 - (I) Line spacing 1.5
 - (II) Justified alignment
- (f) Apply each of the following formats to the text in the document: (2 marks)
- (i) Drop cap to the word “First” in the paragraph with a spacing of 0.75 mm.
 - (ii) Distance from text 0.5mm
 - (iii)Lines to drop 2
- (g) (i) Apply the following indentation features to the paragraph starting with the phrase “The first known population” (2 mark)
- (i) Hanging indentation
 - (ii) 3.05 cm.
- (h) Insert footer on the document as follows: (2 marks)
- (i) Your index number: Left aligned
 - (ii) Insert page number at the top right hand corner of the document.
- (i) Insert a break at the end of the document created such that the new appears section on a new page. (1 mark)
- (j) Insert a text watermark: **Census 2019 Report**, color, red. (2 marks)

- (k) (i) Create the table as it appears below. (4 marks)

Year	Population (millions)
1897	2.5
1948	5.4
1962	8.6
1969	10.9
1979	15.3
1989	21.4
1999	28.7
2009	37.7
2019	47.6

- (ii) Calculate the total population in the years represented above (2marks)
- (iii) Using the table above, create a bar chart to represent the information shown in the following table. (3 marks)
- (iv) Apply a grey background to the chart area created in (i). (1 mark)
- (v) Insert a caption “**CENSUS 2019 REPORT (MILLIONS)**” on the bar chart. (1 mark)
- (vi) Change the orientation of the page containing the chart to landscape. (1 mark)
- (l) Apply line page border of thickness 6 pt to the page containing the chart. (1 mark)
- (m) Save the document and print it on both sides of the paper. (1 mark)

QUESTION 2

(a) Create a new workbook and name it as **form 2 computer Exams.** (1mk)

Name	Class	Adm. No:	CAT 1	CAT2	CAT3	Total	Average	Class Position	Remark
Maina John	E	7984	80	70	59				
Ken Korir	W	7896	75	55	72				
Bernard K.	E	8092	86	59	75				
John Soi	E	7460	80	79	70				
Kipsang Bett	W	7892	76	75	80				
Mitei E.	E	7800	38	48	25				
Mark J.	W	8490	37	51	29				
Koech Ben	W	8184	30	86	75				
James W.	E	8082	25	27	20				
Abuya Ken	E	8083	30	25	25				
Leonand B.	W	8047	39	24	25				

(b) **Enter** the following data in sheet 1 (20 marks)

(c) **Rename** the sheet as Term one results (1 mark)

(d) Find :

i) Totals (2 marks)

ii) Average (2 marks)

(e) Use the **IF** function to award remarks as follow (3 marks)

- A student whose average is above or equals 65 is given "Excellent"
- An average of 55 or above but less than 65 award "average work"
- An average less than 55 award "work below average"

(f)

i) **Award** position to student basing on the average scored. (3 marks)

ii) On the last rows enter formulas to count students from both classes (2 marks)

(g) **Sort** the students list by class position in ascending order. (2 marks)

(h)

i) **Copy** the entire worksheet onto sheet2 and rename it "lower group" (2 marks)

ii) Filter "Lower group" sheet to display students from "E" class and whose average score is below 50. (4 marks)

(i) **Draw** a bar graph to display the following information (3 marks)

- The three cats

- Names
- Title as "TERM ONE COMPUTER RESULTS"
 - i) **Place** the legend at the bottom of the graph (1 mark)
 - ii) **Save** the chart on a new sheet and name it graphical analysis (1 mark)

(j) **Print:**

- i) The filtered lower group (1 mark)
- ii) The chart (1 mark)
- iii) Term one results sheet (1 mark)



BUTERE GIRLS' NATIONAL SCHOOL MOCK EXAMS 2025



Kenya Certificate of Secondary Education

NAME _____ ADM NO _____ CLASS _____

313/1
CHRISTIAN RELIGIOUS EDUCATION
PAPER 1

TIME: 2 ½ HOURS

C. R. E
Paper 1

INSTRUCTIONS TO CANDIDATES:

- This paper consists of **six** questions
- Answer any **five** questions from this paper in the answer booklet provided.

QUESTION	1	2	3	4	5	6	TOTAL
MARKS							

- 1a) Explain how the teaching of Christian Religious Education promotes national unity. 5mks
- b) Identify **seven** deuterocanonical books in the bible. 7mks
- c) State the uses of the bible in Kenya today. 8mks
- 2a) Give **six** characteristics of a covenant. 6mks
- b) Describe the covenant ceremony between God and Abraham according to Gen 1:1-19. 8mks
- c) Write down **six** reasons why Christians condemn female circumcision. 6mks
- 3a) Outline the duties of judges in Israel. 7mks
- b) Give **seven** reasons why Elijah faced danger and hostility as a prophet of God. 7mks
- c) State the forms of corruption found in our society today. 6mks
- 4a) Distinguish between the true prophets and the false prophets in the Old Testament. 8mks
- b) List down the **six** major teachings of Amos. 6mks
- c) State **six** lessons that Christians learn from prophet Amos. 6mks
- 5a) Outline the content of Jeremiah's letter to the exiles.(Jer 29:5-10) 7mks
- b) Identify **eight** occasions when Nehemiah prayed. 8mks
- c) List down the instance when a Christian should pray. 5mks
- 6a) Outline the importance of kinship ties in traditional African society. 7mks
- b) Identify **seven** rules and regulations for the pregnant mothers in African traditional society. 7mks
- c) What are the causes of divorce in Kenya today? 6mks



BUTERE GIRLS' NATIONAL SCHOOL MOCK EXAMS 2025



Kenya Certificate of Secondary Education

NAME _____ ADM NO _____ CLASS _____

313/2
CHRISTIAN RELIGIOUS EDUCATION
PAPER 2

TIME: 2 ½ HOURS

C. R. E
Paper 2

INSTRUCTIONS TO CANDIDATES:

- This paper consists of **six** questions
- Answer any **five** questions in the answer booklet provided.

QUESTION	1	2	3	4	5	6	TOTAL
MARKS							

- 1a) Outline the Jewish expectations concerning the Messiah. 7mks
b) Describe the events that took place when Jesus was born (Luke 2:6-20) 7mks
c) Explain why children should take part in church activities. 6mks
- 2a) Describe the temptations of Jesus in the wilderness according to Luke 4:1-13. 8mks
b) List down **six** qualities of a true disciple from the sermon on the plain. 6mks
c) Identify the temptations that young people may face today. 6mks
- 3a) Outline **seven** events that took place when Jesus was put on the cross. Luke 23:33-46 7mks
b) Give **six** reasons why the disciples found it difficult to believe that Jesus had resurrected. 6mks
c) Why is violence against women rampant in Kenya today. 6mks
- 4a) Outline **eight** reasons why Jesus sent the Holy Spirit to the disciples after his ascension to heaven. 8mks
b) Explain **six** teachings of St. Paul on Christian unity as illustrated in the body of Christ (1st Cor 12: 12-27). 6mks
c) What are the causes of split in the churches in Kenya. 6mks
- 5a) Explain **six** Christian teachings on human sexuality. 6mks
b) State some forms of irresponsible sexual behaviors in modern society. 6mks
c) List down the reasons why Christians condemn irresponsible sexual behavior. 8mks
- 6a) Outline **six** factors that have contributed to high levels of poverty in Kenya today. 6mks
b) Explain **four** negative effects of posed by science and technology on the environment. 8mks
c) Explain the importance of trees to the environment. 6mks

~All the Best~



BUTERE GIRLS' NATIONAL SCHOOL

MOCK EXAMS 2025



Kenya Certificate of Secondary Education

NAME _____ ADM NO _____ CLASS _____

ENGLISH PAPER 101 / 1
FORM FOUR

FUNCTIONAL WRITING, CLOZE TEST AND ORAL SKILLS

TIME: 2 HOURS

INSTRUCTIONS TO CANDIDATES.

- 1) Write your name and index number in the spaces provided.
- 2) Answer all questions in this question paper.
- 3) All your answers should be written in the spaces provided in this question paper.
- 4) Contains seven printed pages.
- 5) All answers should be written in English.

FOR EXAMINER'S USE ONLY.

Question	Maximum Score	Candidate's Score
1	20	
2	10	
3	30	
Total	60	

2. CLOZE TEST

(10 MARKS)

A (1).....was arraigned before the magistrate in the Kilimani law (2)yesterday afternoon. Aged about thirty-three, the man was (3) of trespassing into his neighbour's (4)and stealing oranges. The man however, pleaded not (5) He claimed he did not even know Onyango, the complainant. He even (6) having met him as he escaped with the oranges. The man (7) laughter when he claimed he did not even eat oranges as he is allergic to them. He said Onyango was trying to (8) old scores with him by taking him to court. The magistrate ordered him to be (9) in custody until proper (10) were carried out.

3 (a) *Read the narrative below and answer the questions that follow.*

Farmer Munuve was getting desperate. Someone was stealing his crops of sweet potatoes every night. He decided to set traps to catch the thief. He asked his best and most trusted worker, Monkey, to help him set up the traps. As they worked, Monkey kept singing:

Ke ke ke keee! Goes the trap,

As we tighten the ropes,

Inde, inde,

Ke ke ke keee! Goes the trap!

Every morning for so many days, Farmer Munuve went to the farm to see whether the trap had caught anything. As usual the trap lay there, in ruins, but it had not caught anything. Each time he called Monkey and they set the trap again. While working, Monkey kept singing in his own language:

Ke ke ke keee! Goes the trap,

As we tighten the ropes,

Kachaaa! Goes the trap,

Inde, inde,

When it opens, Kachaaa!

Monkey did not know that Farmer Munuve knew Monkey's language and spoke it fluently. One day, he listened to the words carefully and it dawned on him that the one worker he had trusted much was the one who had been stealing from him how would you prepare to perform the story to a live audience.

i) As a narrator, mention **three** things you would do to prepare for the performance of this story. (3 marks)

.....
.....
.....
.....
.....

ii) As part of the audience, how would you encourage the narrator to keep going? (3 marks)

.....
.....
.....
.....
.....

iii) As the narrator, describe one verbal and one non-verbal cue you would use to make your performance interesting. (4 marks)

.....
.....
.....
.....
.....
.....

b) Which intonation would you use to say each of the following sentences? (4 marks)

- i. What a day!
- ii. He will visit our school before April, wouldn't he?
- iii. Have you taken any medication?
- iv) How do you do?

c) Read the passage below and identify three ways Jared violated personal space boundaries in this scenario. (3 marks)

When Miriam walked into the staff lounge, she noticed Jared had taken over the entire couch, with papers, folders, and snacks scattered everywhere. “Could you please make some room?” Miriam asked politely. “I need to sit and get some work done.” Jared rolled his eyes. “You’re always complaining,” he muttered. Then he shifted slightly but left most of the couch cluttered. As Miriam sat at the edge, Jared leaned towards her, speaking loudly right next to her ear. He then reached across her without warning to grab a folder from the table in front of her, brushing against her arm.

.....

.....

.....

.....

.....

.....

d) Two of your friends are involved in a serious disagreement and have asked you to mediate. State three conflict negotiation skills you would use to help resolve the situation effectively? (3 marks)

.....

.....

.....

.....

.....

e) You attend a prize-giving ceremony in your school. When the chief guest is speaking. You notice that he is sweating profusely, he is in audible, and he stammers a lot and avoids eye contact with his audience. What could be the cause of such behaviour? (4 marks)

.....

.....

.....

.....

.....

.....

.....

.....

.....

.....

f) Study the conversation below and with illustrations, identify how the speakers display telephone etiquette. (6 marks)

Secretary: Good morning, this is Sagrada Secondary School. How may I assist you?

Mr. Mutuma: Good morning. Could I please speak with Mr. Gitonga?

Secretary: I'm sorry, but Mr. Gitonga is currently unavailable. Would you like to leave a message for him?

Mr. Mutuma: Yes, thank you. Please let him know that Mr. Mutuma from Graphic Designs Centre called to confirm the order for the display posters.

Secretary: Certainly. May I have your contact number, please?

Mr. Mutuma: Yes, it's 0727 139 907.

Secretary: That's 0-7-2-7-1-3-9-9-0-7. Did I get that right?

Mr. Mutuma: Yes, that's correct. And who am I speaking with?

Secretary: This is Miss Nicole, the receptionist.

Mr. Mutuma: Thank you, Miss Nicole. Have a great day.

Secretary: You too. Thank you for calling.

.....

.....

.....

.....

.....

.....

.....

.....

.....



BUTEREGIRLS'NATIONALSCHOOL

MOCK EXAMS 2025



Kenya Certificate of Secondary Education

NAME _____ ADM NO _____ CLASS _____

101/2

ENGLISH

PAPER 2

(Comprehension, Literary Appreciation and Grammar)

Time: 2 ½ Hours

INSTRUCTIONS TO CANDIDATES

1. Write your name and index number in the spaces provided above
2. Sign and write the date of examination in the spaces provided above
3. Answer ALL questions in this question paper
4. ALL your answers must be written in the spaces provided in this question paper

FOR EXAMINER'S USE ONLY

QUESTION	MAXIMUM SCORE	CANDIDATES SCORE
1	20	
2	25	
3	20	
4	15	
TOTAL SCORE	80	

This paper consists of 12 printed pages.

Candidates should check the question paper to ensure that all pages are printed as indicated and no questions are missing

QUESTION 1: COMPREHENSION

(20 MARKS)

Read the passage below then answer the questions that follow:

My favourite aunt is a woman anyone would admire, both her physical features and character. She is the kind of person you want to be with all the time.

She is the eldest in my father's family but she looks the youngest. Though in her mid-sixties, she looks twenty years younger. It is as if she has signed a contract with perpetual youth. I have heard countless people ask her what her secret is, upon which she readily replies with a winsome smile. "I don't look back in regret or look around in worry. Instead, I always look up in hope." I don't know, but I am tempted to believe that this philosophy has kept away the gnawing tooth of time.

At about five feet, her height wouldn't catch the eye of a basketball coach. However, it goes well with her body on which there isn't an ounce of flabby flesh. Actually, the ravages of multiple childbirth and age have not robbed her of her waistline and shapely figure. For one who has never heard of a gym let alone worked out in one, she is nicely put together.

One grudge that I have against her is that she inherited the very best that her parents had to offer in terms of hair, leaving my dad with stingy strands that you can almost count. No wonder mine defies even the most qualified stylist. When she was younger, my aunt liked to display hers in fancy hair-dos. I have seen earlier photographs in which it is shiny black, shoulder length and full bodied. Today, it has thinned a little and is no longer as long due to breakage. Shy streaks of gray are appearing but if you consider that some people twenty years her junior are already white-haired then you must concede that it is one of her best features. She usually plaits it into two thick knots, one at the front and the other at the back. She then covers it with a headscarf as is required by her denomination.

She denies it but I bet that her face earned her many male stares when she was young. Dark in complexion, it is still smooth and even in tone though edged with tiny lines... I don't like to call them wrinkles. Her eyes are bright with hope and wisdom. Even when she is sad, they retain their lustre and intensity. Her arched bushy eyebrows seem to be guarding these gems zealously. To complete the picture, her nose and mouth complement her rounded face perfectly. Her husband, my uncle, often teasingly tells her that her lips are a little too thick. Being one to never lack a quick response or take offense easily, she quips: "Well the thicker the better to declare my overflowing love for you." For me, they are a reflection of her generous spirit.

Although she is not a fashion enthusiast, my aunt knows a thing or two about dressing smartly and elegantly. Her ankle – length pleated dresses are always neatly pressed and matched with the headscarf. She is fussy about who makes her outfits because she wants them to come out just right. I am sure she had sampled several seamstresses before she settled on her current one to whom I have been introduced. Navy blue is her favourite colour. I have heard it said that it is the colour of confidence and if my aunt is anything to go by, I think it is true.

In the entire neighbourhood, she is known as "Mama Safi." A former customer of hers tells me the nickname is two-fold. "years ago, she used to run a shop named so and she grew to become synonymous with it, hence the nickname. But the story doesn't begin there. When she opened the shop, it was simply known as "Duka". She would sweep in front of it every so often and sprinkle water to keep away dust. Inside the items were neatly arranged

according to their types and sizes. If she accidentally spilt substances like milk and sugar, she would immediately clean up the mess.”

Perhaps you are wondering why I like Auntie Joyce so much. Well, we, her nieces and nephews concur that she does many things for us. She spoils us the way only a grandmother can, she advises us the way only an aunt can, imparting **pearls of wisdom** when the girls confide their men’s troubles in her; she supports us the way only friends can – listening to our side of the story when our parents fail to.

(Taken from **Secret from Beyond**; Oloo Oliver, unpublished)

QUESTIONS

a) According to the passage why is the narrator’s aunt her favourite? (2 marks)

.....
.....
.....

b) What is the secret behind the narrator’s aunt’s youthful appearance? (2 marks)

.....
.....
.....

c) Why does the narrator begrudge her favourite aunt? (2 marks)

.....
.....
.....

d) She is the kind of person you want to be with all the time. (Rewrite adding a question tag) (1 mark)

.....
.....

e) How can we tell that the narrator’s aunt is aging? (2 marks)

.....
.....
.....
.....

f) Describe the relationship between the narrator's aunt and her uncle. (2 marks)

.....
.....
.....

g) Explain why 'gym' is mentioned in this passage. (2 marks)

.....
.....
.....

h) What evidence is there in the passage to show that the narrator's aunt wants her to follow in her footsteps? (2 marks)

.....
.....
.....
.....

i) List why the narrator's favourite aunt is liked by the nieces and nephews. (2 marks)

.....
.....
.....
.....

j) Explain the meaning of the following expressions as used in the passage. (3 marks)

i) Signed a contract with perpetual youth.

.....

ii) Earned her many male stares.

.....

iii) Pearls of wisdom.

.....

QUESTION 2: THE SAMARITAN

(25 MARKS)

Read the following excerpt and then answer the questions that follow.

Bembe: You have a reputation for being too strong-willed to be suitable for a school teacher. You're as stubborn as a mule.

Nicole: What crime is that?

Bembe: Well, it is not a crime as such; but don't you think it is a bad influence to the students?

(Bangs the table violently and shouts an order. Two police officers enter.) Handcuff her! *(There is a commotion as the officers reach out to Nicole. She resists but is overpowered. There is an interval of silence as Bembe begins to rummage through papers on Nicole's table. Nicole refuses to move and sits down on the floor. The officers drug her on the floor)* Stop. *(The officers stop. There is silence. Then Bembe moves behind Nicole's table and starts pulling the drawers open, one after the other, removing and throwing papers all over the floor.)* Where have you hidden it?

Nicole: Hidden what?

Bembe: The Samaritan! *(Nicole is visibly surprised at the answer but remains silent)* I will tell you this, whenever you see me personally involved in an arrest, you must know it's a serious matter, as serious as death. And you should be afraid. Very afraid!

Nicole: I am not guilty of anything, and I refuse to be **intimidated!**

Bembe: *(Inspector Bembe bangs the table violently with his gun. Nicole recoils with a start.)* Woman! Show some seriousness! This is no laughing matter. Are you willing to talk?

Nicole: About what? *(There is silence as Inspector Bembe wears his beret and places his sceptre under his armpit)*

Bembe: About The Samaritan.

Nicole: What about The Samaritan?

Bembe: Where is it?

Nicole: I don't understand you?

Bembe: Where is it? *(He repeats angrily)*

Nicole: *(Swinging her head in disbelief)* I have no such thing in my possession, but you can download it from the internet.

Bembe: *(Hitting Nicole on the face with a bunch of papers)* Now you have to tell those two students to shut that thing off. Alright?

Nicole: Why should I?

Bembe: Because it is the right thing to do!

Nicole: I have no right to dictate what they do with their App.

Bembe: Then you have to shut it down yourself! We believe The Samaritan is your **brainchild!**

The two students are just a cover-up! And the App is a **grave** danger to society!

Nicole: Mr. Inspector, when The Samaritan helps us fight environmental degradation by exposing the culprits, is that dangerous?

Bembe: Fighting environmental degradation is none of the school's business! We have competent agencies employed to do that! Teach the authorized curriculum.

Nicole: When it helps us to know who supplies air to the Municipal Council instead of goods and services, is that dangerous?

QUESTIONS

a) Explain what happens before this excerpt. (3 marks)

.....
.....
.....
.....
.....

b) In the light of what has been happening in the text, why does Inspector Bembe tell Nicole that she has a reputation for being too strong-willed to be suitable for a school teacher? (2 marks)

.....
.....
.....
.....

c) Discuss two thematic concerns of the writer raised in the excerpt. (4 marks)

.....
.....
.....
.....
.....
.....

d) Identify the character traits of Inspector Bembe and Nicole as brought out in this excerpt:

i) Inspector Bembe. (2 marks)

.....
.....
.....
.....

ii) Nicole. (2 marks)

.....
.....
.....
.....

e) With reference to the rest of the play, what became of Nicole after the arrest by Inspector Bembe? (3 marks)

.....
.....
.....
.....
.....

f) You're as stubborn as a mule. (Rewrite adding a question tag) (1 mark)

.....

g) Are you threatening a police officer? (Change the interrogative into a statement.) (1 mark)

.....
.....

h) Pick out two stylistics devices employed in the excerpt and illustrate them. (4 marks)

.....
.....
.....
.....
.....
.....

i) Explain the meanings of the following words used in the excerpt. (3 marks)

- i) Intimidated.....
- ii) Brainchild.....
- iii) Grave

QUESTION 3: POETRY

(20 MARKS)

Read the poem below and answer the questions that follow.

BACK HOME

And one day I went back home:
Back home to the old homestead
With a ring of old huts
Surrounding a wide compound:

Swept clean for children to play
And yell and laugh and cry.
I walked briskly, thinking of home
Smoke rising from the huts
Filtered through the thatched roofs:

Dripping wet after a shower of rain;
Moist ground in the compound,
Grandpa sitting on his stool
And sipping from his gourd;
Birds singing in the mango tree:

And then finally I reached home:
The air heavy with silence
Huts, down in dry heaps of dilapidation
Shoots of scorched elephant grass:
Growing piously in the compound:

A carpet of mango leaves
Falling on the mound of earth
Under which was buried but the tip
Yes, only the tip of grandpa's walking staff
Could be seen peeping from under the earth:

Pointing down to where the owner lay;
The lasting indication
Of his inability to talk again
Except by echoes of silence
Telling me I went back too late:

Twani Mwaikusa.

Questions

(a) Who is the persona in the poem?

(2 marks)

.....
.....

(b) What is the poem about? (3 marks)

.....
.....
.....
.....

(c) Identify and illustrate the persona's character trait. (4 marks)

.....
.....
.....
.....
.....

(d) Where is grandpa? Give a reason for your answer. (2 marks)

.....
.....

(e) What is the mood of the poem? (3 marks)

.....
.....
.....

(f) Explain any two features of style used in the poem. (4 marks)

.....
.....
.....
.....
.....

(g) Explain the meaning of the following lines as used in the poem. (2 marks)

‘Of his inability to talk again
Except by echoes of silence’

.....
.....

QUESTION 4: GRAMMAR

(15 MARKS)

a) Choose the correct alternative to complete the sentences.

(3 marks)

- i) ii) It hurts to..... (loose/lose) a friend.
- ii) Since last year,..... of theft have reduced. (incidence, incidents)
- iii) Could you (sent, send) a reply to them as quickly as possible?

b) Use a preposition to complete the following sentences.

(3 marks)

- i) My uncle deals second hand clothes.
- ii) The train went the tunnel.
- iii) Wekesa mistook Wambui her sister.

c) Rewrite the following sentences as instructed.

(3 marks)

- i) Of the two books, the first is longest. (Rewrite to correct the error)

.....

- iii) The snake did not bite the boy (Begin: The boy...)

.....

- iii) Jane is both humble and obedient. (Rewrite using: Not only.....)

.....

d) Fill in the blank spaces with the most appropriate pronoun.

(3 marks)

- i) He plays the guitar better than (me, I)
- ii) He bought a loaf for Mercy and (he, him)
- iii) It was (he, him) that won the race.

e) Replace the underlined words with the correct phrasal verb formed from the word in brackets

(3 marks)

- i) Kirui withdrew from the London marathon due to a knee injury. (pull)

.....

- ii) I can't tolerate my neighbour's noise any longer; it's driving me mad. (put)

.....

- iii) He had his dog killed because it was in a lot of pain from its tumours. (put)

.....



BUTERE GIRLS' NATIONAL SCHOOL

MOCK EXAMS 2025



Kenya Certificate of Secondary Education

NAME _____ ADM NO _____ CLASS _____

101/3

ENGLISH

PAPER 3 (IMAGINATIVE, COMPOSITION AND ESSAYS BASED ON SET TEXTS)

FORM FOUR

TIME: 2 HOURS 30 MINUTES

INSTRUCTIONS TO CANDIDATES

- a) Answer three questions only.
- b) Questions two and three are compulsory
- c) Each of your essays must not exceed 450 words
- d) All answers to be written in the answer booklet provided candidates should check the question paper to ascertain that all the pages are printed as indicated and that no questions are missing.

Q1. Imaginative composition (Compulsory) (20 marks)

Either

(a) Write a story ending with;

..... Truth be told, we strongly believe that he was innocent. (20 marks)

Or

(b) Write a composition explaining what the Kenyan youth can do to help in the fight against corruption. (20 marks)

Q2. The Compulsory Set Text (20 marks)

PAUL B. VITTA, *Fathers of Nations*

Seeking revenge results in more pain. Using illustrations from *Fathers of Nations*, write an essay to support this statement.

Q3. Optional texts

(a) The short story

Godwin Siundu (Ed.), A Silent Song and Other Stories. (20 Marks)

Mental illness causes serious challenges not only to the patients but also to those close to them. Write an essay illustrating the truth of this statement using illustrations from Filemon Liyambo's story *December*. (20 marks)

(b) Drama

Adipo Sidang' – Parliament of Owls. (20 Marks)

"Women and people from minority groups can rise against all odds to bring change without necessarily using violence." Basing your argument on Adipo Sidang's *Parliament of Owls*, write an essay to support this statement.

(c) The Novel

Kazuo Ishiguro, An artist of the Floating World. (20 Marks)

Some events that we pass through in our lives affect us for a long time. Discuss the relevance of this statement basing your illustrations on Kazuo Ishiguro's *An Artist of the Floating World*.



BUTERE GIRLS' NATIONAL SCHOOL MOCK EXAMS 2025



Kenya Certificate of Secondary Education

NAME _____ ADM NO _____ CLASS _____

312/1
GEOGRAPHY
PAPER 1

TIME: 2 $\frac{3}{4}$ HOURS

Geography
Paper 1

INSTRUCTIONS TO CANDIDATES:

- This paper consists of **two** sections: **A** and **B**
- Answer **all** the questions in section **A**
- Answer question **6** and **any two** questions from **section B**
- All answers **must** be written in the answer booklet provided

Answer all questions in this section

- 1.a) Define the term rotation of the earth. (2 Mks)
b) State **three** factors that contribute to the geoid spheroid shape of the earth. (3 Mks)
- 2.a) Give **three** methods of predicting weather (3 Mks)
b) Why is weather predictions by the weather man in the recent past not been accurate. (2 Mks)
- 3.a) What is folding? (2 Mks)
b) What determines the extent of folding that takes place in a given area? (3 Mks)
- 4.a) Define the term lake. (2 Mks)
b) Give **three** factors that determine the permanence of a lake. (3 Mks)
5. State **five** natural causes of aridity and desertification (5 Mks)

SECTION B

6. Study the map of TAMBACH, 1:50,000 and answer the following questions
- a. What is the title of the map provided (1 Mk)
- b. (i) Name two types of scales found on the map (2Mks)
(ii) Convert the scale of the map into statement scale (2 Mks)
- c. (i) What is the magnetic declination of the map as at 1980 (2 Mks)
(ii) Name the index number and the area bordering Tambach to the east (1 Mk)
- d. (i) Identify two human features found on the grid square 7979 (2 Mks)
(ii) State the six-figure grid reference for the school at Kapluk (2Mks)
- e. (i) Describe the relief of the area covered by the map (5 Mks)
(ii) Citing evidence from the map, describe the social functions of Tambach town (3 Mks)
- f. Using a vertical scale of 1cm representing 40 metres, draw a cross section from grid reference 830610 to grid 890610. On the cross section, mark and label the following features (5 Mks)
- I. Road C52
 - II. Foot path
 - III. River Torok
 - IV. Hill

- 7.(a) (i) What is a rock? (2 Mks)
- ii) State **two** reasons why sedimentary rocks are wide spread in the Coastal plain (2 Mks)
- (b)For each of the following rocks, name the resultant rock formed after metamorphism
- (i) Sandstone (1 Mk)
- (ii) Limestone (1 Mk)
- (iii) Granite (1 Mk)
- (c)(i)Describe how extrusive igneous rocks are formed (4 Mks)
- ii)List **two** examples of extrusive rocks (2 Mks)
- (d)Explain **three** economic significance of rocks in Kenya. (6 Mks)
- (e)Students carried out a field study on rocks around their school.
- (i)State **two** objectives they formulated (2 Mks)
- (ii)Give **two** reasons why they prepared a route map. (2 Mks)
- (iii)Give **two** activities that the students were involved in during the fieldstudy (2 Mks)

8. (a) List **three** factors which contribute to the development of deserts. (3mrks)
- (b) Name **three** processes through which wind erodes a desert landscape. (3mrks)
- (c) Explain **three** ways through which wind transports its load. (6mrks)
- (d) Describe how the following desert features are formed. (9mrks)
- (i) Yardangs.
- (ii) Rock pedestals.
- (iii) Wadis.
- (e) State **four** ways in which desert features are significant to human activities. (4mrks)

9. Use the diagram below to answer question (a).

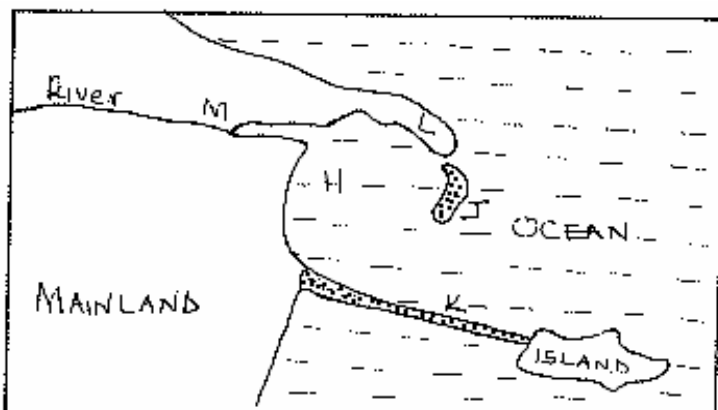

- (a) Name the Coastal features marked **H, J, K, L** and **M**. (5mrks)
- (b) (i) State **four** conditions necessary for the formation of a beach. (4mrks)
(ii) Describe how a bird's foot delta is formed. (4mrks)
- (c) Describe **three** processes involved in Marine erosion. (6mrks)
- (d) You are planning to carry out a field study on the depositional features along the Coast of Kenya.
(i) State **three** objectives you would formulate for your study. (3mrks)
(ii) Give **three** methods you would use to record the information collected. (3mrks)
- 10.(a)(i) State two days in a year when the length of day and night is equal. (2mks)
ii) Draw a well labelled diagram to show the eclipse of the moon (Lunar eclipse) (3mks)
- (b)(i) Give **four** characteristics of planet Jupiter. (4mks)
(ii) Give **three** possible consequences of the revolution of the earth on lengths of days and nights. (3mks)
- (c)(i) Name **three** instruments found in a Stevenson screen. (3mks)
ii) State and explain **four** qualifications which makes Stevenson screen suitable for its work. (4mks)
- d) With the help of a well labelled diagram, explain the formation of frontal /cyclonic rainfall. (6mks)



BUTERE GIRLS' NATIONAL SCHOOL MOCK EXAMS 2025



Kenya Certificate of Secondary Education

NAME _____ ADM NO _____ CLASS _____

312/2
GEOGRAPHY
PAPER 2

TIME: 2 ³/₄ HOURS

**Geography
Paper 2**

INSTRUCTIONS TO CANDIDATES:

- This paper consists of **two** sections: **A** and **B**
- Answer **all** the questions in section **A**
- Answer question **6** and **any two** questions from **section B**
- All answers **must** be written in the answer booklet provided

SECTION A.

Answer all questions in this section.

- 1.(a) What is mining? (2mks)
- (b) State 3 benefits of soda Ash mining to the economy of Kenya. (3mks)
- 2.(a) State 2 factors that determine the distribution of forest in KENYA. (2mks)
- b) State 3 factors that have led to the reduction of the area under forest on the slopes of Mt. Kenya. (3mks)
- 3.(a) State 2 factors that hinder domestic tourism in KENYA. (2mks)
- (b) Give measures taken by the East African countries to manage wildlife. (3mks)
- 4.(a) Give 2 methods used to reclaim land in Kenya. (2mks)
- (b) State 3 problems experienced in irrigation farming in Kenya. (3mks)
- 5.(a) Apart from floods and environmental pollution, name any other 3 environmental hazards. (3mks)
- (b) Give 2 reasons why it is necessary for Kenya to conserve the environment. (2mks)

SECTION B

Answer QUESTION 6 and any other two questions from this section.

6. The table below shows items exported from forest products in Kenya. Use it to answer questions 6 (a) (i) and (ii)

EXPORT PRODUCTION	WEIGHT IN TONNES
Plywood	12,600
Veneers	9,990
News print	1,560
Block board	750
TOTAL	24,900

- (a) i. Name the main export item (1mark)
- ii. Draw a divided rectangle 15cm long to represent the above information. (8marks)
- (b) i. What is agro-forestry? (2marks)
- ii. Give five reasons why afforestation is being encouraged in Kenya. (5marks)
- iii. State three factors that have led to reduction of the area under forest in Kenya. (3marks)
- (c) Explain problems that affect forestry in Canada. (6marks)
7. (a) (i) What is visible trade? (2marks)
- (ii) List **three** major imports to Kenya from Japan. (3marks)
- (b) Explain **four** factors that influence internal trade in Kenya. (8marks)
-

- (c) State **four** ways in which trade is of significance to Kenya. (4marks)
- (d) Explain **four** benefits which member states of SADC derive from the formation of the trading bloc. (8marks)

8.(a) Define the following terms:

- i. Fertility. (2marks)
- ii. Fecundity (2 marks)
- (b) i. Explain three problems that result from high population growth in Kenya. (6 marks)
- ii. Highlight any four differences between Kenya's population and that of Sweden. (8 marks)
- (c) State causes of the rural - rural migration in East Africa. (4 marks)
- (d) State any three factors influencing population distribution in East Africa. (3 marks)

9.(a) (i) Apart from windstorms name **two** other environmental hazards associated with climatic conditions. (2marks)

(ii) State **three** problems caused by windstorms in Kenya. (3marks)

(b)(i) Name **two** rivers in Kenya to the West of the Rift Valley which cause large scale flooding. (2marks)

(ii) Explain **four** problems caused by floods. (8marks)

(c) (i) Explain **three** effects of land pollution on the environment. (6marks)

(ii) State **four** ways through which land pollution can be controlled. (4marks)

10. (a) Name **three** types of dairy cattle kept in Kenya (3 marks)

(b) (i) State **four** condition that favour dairy farming in the Kenyan highlands. (4 marks)

(ii) Explain **three** problems facing dairy farmers in Kenya. (6 marks)

(c)(i) State **three** measures the government of Kenya is taking to improve dairy farming (3 marks)

(ii) Compare dairy farming in Kenya and Denmark. (4 marks)

(d) You intend to carry out a field study in a dairy farm.

(i) Give three methods you would use to collect information. (3 marks)

ii) State two follow up activities you would carry out after the field study. (2 marks)



BUTERE GIRLS' NATIONAL SCHOOL MOCK EXAMS 2025



Kenya Certificate of Secondary Education

NAME _____ ADM NO _____ CLASS _____

311/1
HISTORY & GOVERNMENT
PAPER 1

TIME: 2 ½ HOURS

History & Government

Paper 1

INSTRUCTIONS TO THE CANDIDATES: -

- This paper consists of **three** sections; **A, B, & C**
- Answer **all** questions in section **A**, **three** questions in section **B** and any **two** questions in section **C**.
- Answers to all questions **must** be written in the separate sheets provided.
- Candidate should answer the questions in English.

SECTION A:**25 MARKS****Answer all questions from this section**

1. State the branch of history that deals with the cultural activities of man (1mk)
2. Name the species that was discovered at Fort Ternan (1mk)
3. Name two sub-group of Eastern Cushites (2mks)
4. State two ways in which citizenship acquired by registration may be revoked (2mks)
5. State two characteristics of human rights in Kenya (2mks)
6. Give two factor that led to the growth of Nairobi as a modern urban centre (2mks)
7. State one strategic factor that led to the scramble and partition of East Africa (1mk)
8. Identify the main reason why kipande system was introduced in Kenya during the pre-colonial period (1mk)
9. Name two newspapers that voiced Africans grievances in colonial Kenya up to 1943. (2mks)
10. What is the main voting method that is used in Kenya during general elections (1mk)
11. Who is the head of the national police service? (1mk)
12. What is the meaning of devolved government? (1mk)
13. Give one example of indirect taxes in Kenya (1mk)
14. Name the two organs that make up the county government in Kenya. (2mks)
15. Identify two sources of Nyayoism (2mks)
16. Identify one main component of the budget in Kenya (1mk)
17. Name two types of public expenditure (2mks)

SECTION B:**45 MARKS****Answer any three questions from this section**

- 18 (a) State three functions of the council of elders among the Luo in pre-colonial Kenya. (3mks)
(b) Describe the social organization of the Agikuyu during the pre-colonial period (12mks)
19. (a) State five factors that promoted the development of plantation agriculture at the East African coast (5mks)
(b) Explain five factors that hindered the work of early Christian missionaries in Kenya (10mks)
20. (a) Give five levels of colonial administration in Kenya (5mks)
(b) Explain five reasons why the British used indirect rule in some parts of Kenya during colonial period (10mks)
21. (a) Identify three groups which provides health services in Kenya (3mks)
(b) Explain six challenges facing the education sector in Kenya today (12mks)

SECTION C:**30MARKS****Answer any two questions from this section**

22. (a) Identify three circumstances that may make the deputy president assume presidency in Kenya (3mks)
- (b) Explain six reasons why parliament is regarded as supreme in Kenya (12mks)
23. (a) Outline the composition of the county executive Committee in Kenya (3mks)
- (b) Explain six functions of county governments in Kenya (12mks)
24. (a) Identify five importance of the National Budget (5mks)
- (b) Explain five sources of revenue for the County Governments in Kenya (10mks)



BUTERE GIRLS' NATIONAL SCHOOL MOCK EXAMS 2025



Kenya Certificate of Secondary Education

NAME _____ ADM NO _____ CLASS _____

311/2
HISTORY & GOVERNMENT
PAPER 2

TIME: 2 ½ HOURS

History & Government

Paper 2

INSTRUCTIONS TO THE CANDIDATES:-

- This paper consists of **three** sections; **A, B, & C**
- Answer **all** questions in section **A**, **three** questions in section **B** and any **two** questions in section **C**.
- Answers to all questions **must** be written in the separate sheets provided.
- Candidate should answer the questions in English.

FOR EXAMINER'S USE ONLY:

SECTION	QUESTIONS	CANDIDATE'S SCORE
A	1- 17	
B	18	
	19	
	20	
	21	
C	22	
	23	
	24	
	TOTAL	

Answer all the questions from this section

1. State two methods used by archaeologist to date fossils and artefacts (2mks)
2. Name two types of oldwan tools (2mk)
3. State the main contribution of Robert Bakewell in agrarian revolution (1mk)
4. Identify the main commodity from Africa during the Trans-Atlantic trade (1mk)
5. Highlight two disadvantages of railway transport (2mks)
6. Identify two factors to consider when sending a message (2mks)
7. Identify one metal that was used during industrial revolution (1mk)
8. State two factors that led to decline of kilwa as an urban centre (2mks)
9. State two social factors that led to majimaji rebellion (2mks)
10. Why did the white settlers in Zimbabwe choose to establish self-government (1mk)
11. Identify two political reforms introduced by President Frederick De Klerk that led to attainment of majority rule in South Africa (2mks)
12. State two roles played by USA in ending World War II (2mks)
13. Give one official language of the united Nation (1mk)
14. State one member state of the COMESA who is from North Africa (1mk)
15. How does poverty undermine economic growth in Tanzania since independence? (1mks)
16. State one major political party in Britain (1mk)
17. Who is the head of government in India (1mk)

SECTION B: 45MARKS**Answer any three questions from this section**

18. (a) Highlight the characteristics of Agrarian Revolution in USA (5mks)
(b) What are the effects of food shortage (10mks)
19. (a) State five challenges faced by Trans-Saharan traders (5mks)
(b) What led to decline of Trans -Atlantic trade (10mks)
20. (a) Outline five economic activities of the Asante during the 19th Century (5mks)
(b) Describe the political organization of the Buganda during the 19th Century (10mks)
21. (a) State five factors that led to rise of nationalism in Mozambique (5mks)
(b) Explain five reasons why FRELIMO succeeded in its armed struggle against Portuguese (10mks)

SECTION C: 30MARKS

Answer any two questions from this section

22. (a) Mention three aims of league of Nation (3mks)
(b) Explain six causes of cold war (12mks)
23. (a) Who were the founders of East Africa community (3mks)
(b) Explain political challenges which were experienced in Democratic Republic of Congo at independence (12mks)
24. (a) State three functions of legislature in India (3mks)
(b) Explain six roles of state government in USA (12mks)



BUTERE GIRLS' NATIONAL SCHOOL MOCK EXAMS 2025



Kenya Certificate of Secondary Education

NAME _____ ADM NO _____ CLASS _____

102/1
KISWAHILI
KARATASI YA 1

MUDA: SAA 1 $\frac{3}{4}$

Kiswahili
Insha

MAAGIZO

- Jibu maswali mawili*
- Swali la kwanza ni la lazima*
- Kisha chagua swali lingine kutoka hayo matatu yaliyosalia*
- Kila insha isipungue maneno 400*
- Kila insha ina alama 20*
- Majibu yote **lazima** yaandikwe kwa lugha ya Kiswahili.*

Swali la lazima

1. Wewe kama rais umekerwa na kukithiri kwa ufisadi katika wizara mbalimbali. Andikia **arifa/memo** mawaziri wako ukiwaeleza madhara ya ufisadi na hatua utakazochukua ikiwa hawatakomesha ufisadi katika wizara zao.

Chagua swali lingine moja kutokana na haya:

2

- a) Nyimbo za kitamaduni zilikuwa na nafasi kubwa katika ufanisi wa jamii kwa jumla. Eleza.
- b) Andika kisa kitakachodhihirisha ukweli wa: Heri ya mrama kuliko ya kuzama.
- c) Andika insha itakayomalizika kwa maneno yafuatayo:

“Kwa hakika vijana wanafaa kuelekezwa jinsi ya kudhibiti hasira na hisia ili kuzuia hasara kama hiyo.” Sakiti alijisemea kwa majonzi.



BUTERE GIRLS' NATIONAL SCHOOL MOCK EXAMS 2025



Kenya Certificate of Secondary Education

NAME _____ ADM NO _____ CLASS _____

102/2
KISWAHILI
LUGHA
KARATASI YA 2

MUDA: SAA 2 ½

KISWAHILI
Lugha

MAAGIZO

- *Andikajinalakonambayakokatikanafasiulizoachiwahapojuu.*
- *Weka **sahihiyakonatarehe**yamtihanikatikanafasiulizoachiwa*
- *Jibumaswali yote.*
- *Majibuyaandikwekatikanafasizilizoachwawazikatikakijitabuhiki cha maswali.*

KWA MATUMIZI YA MTAHINI PEKEE.

SWALI	UPEO	ALAMA
1	15	
2	15	
3	40	
4	10	
JUMLA	80	

Soma makala haya kisha ujibu maswali

Waswahili wanasema kuwa mbiu ya mgambo ikilia kuna jambo. Wanasayansi wamekuwa wakitoa habari za kuhuzunisha kuhusu hali joto ulimwenguni. Uchunguzi wao unabainisha kuwa kiwango cha hali joto kinazidi kupanda. Hii inaonyesha kuwa mazingira yetu yanazidi kupoteza unyevu na badala yake hali ya ukavu inashamiri. Hali hii inatia wasiwasi mno. Ulimwengu mzima sasa unajitahidi kuyatilia mkazo mazingira kwa kuwataka watu wote kuyahifadhi na kuyarejesha katika hali yake ya awali.

Katika mataifa yanayoendelea, watu hukata miti na kuchoma makaa kama njia ya kupata kawi iliyo muhimu katika shughuli za uandaaji wa mila. Wengine hukata miti kusudi wapate kuni. Wengine nao hukata miti ili waweze kupasua mbao za kujenga na pia kutengeneza samani na vifaa vinginevyo. Haja za miti si haba. Pamoja na kwamba haja hizi ni lazima kutimizwa, miti imekuwa ikikatwa tu bila kujali viwango vya ukataji huo au kupanda mingine kuziba pengo la ile iliyokatwa. Matokeo yake ni watu wachache walafi kujitajirisha ilhali kizazi kizima kinaangamia. Ukataji miti huivua ardhi na kuiacha uchi. Mvua inaponyesha udongo wenye rutuba husombwa na kupelekwa baharini. Vilevile ukosefu huu wa miti unamaanisha kuwa unyevunyevu ulio muhimu katika hatima ya kuleta mvua haupo. Mavuno yake ni kiangazi. Ukame, njaa, jangwa na maangamizi. Tayari tumeshuhudia hapa nchini mwetu jinsi vipindi vya ukame vinazidi kuwa virefu kuliko awali. Kwa mara kadha sasa tumekuwa na mgao wa umeme kwa vipimo, mgao wa maji kwa vipimo na kadhalika. Hizi zote ni athari za kutoyajali mazingira yetu.

Sehemu za ulimwengu zilizoendelea kiteknologia zina matatizo ya aina yake. Ongezeko la magari na viwanda katika nchi hizo sasa vimeanza kuwatia wenyewe joto. Magari yanatoa mioshi iliyo hatari kwa afya ya watu na mazingira kwa jumla. Katika baadhi ya miji ya nchi hizo zilizoendelea, vimerekodiwa visa vya maji meusi tititi ya mvua. Kisa na maana ni kwamba wamezichafua anga zao kupitia mioshi itokayo viwandani na kwenye magari. Maji hayo si salama kwa matumizi ya binadamu wala mimea na wanyama. Katika baadhi ya miji wingu jeusi huwa limetanda utadhani ni giza lililoingia majira ya aduhuri. Ni hayo sasa yamebuni sheria kali ambazo zinalenga kuyaokoa mazingira yao.

Nchi nyingi ulimwenguni zimeandika na kutia sahihi mikataba ambayo inapiga vita kutumiwa mafuta ya risasi na kuanza kutumia isiyoye risasi. Nchi nyingi sasa zanaelekea

kutupilia mbali matumizi ya petroli au diseli ya risasi na kuanza kutumia isiyo ya risasi. Wataalamu wanasayansi wamebaini kuwa mafuta ya risasi yana athari mbaya kwa mazingira. Yenye ni tishio kwa afya ya mwanadamu.

Katika sekta ya mazao na kilimo, wanasayansi walipoona kuwa ulimwengu ulikuwa unakabiliwa na tishio la njaa kufuatia uhaba wa chakula, hawakusita kubuni mbinu mpya za kuzidisha mazao. Mojawapo na hii ni ya awali kabisa, ni kutumia mbolea zilizotengenezwa viwandani kuiongezea ardhi rutuba. Uvumbuzi wa baadaye umeonyesha kwamba mbolea hizi zina kemikali ambazo hufyonzwa na mimea ya chakula. Mimea hii inapokomaa na kuanza kutumiwa na mwanadamu kama chakula, humletea madhara katika afya yake. Baadhi ya kemikali hizo, hukokotwa hadi kwenye maziwa na bahari zetu ambamo muna samaki. Samaki hawa, mbali na kuathiriwa na kemikali hizo hatimaye huingia katika mwili wa mwanadamu na kuanza kuitatiza afya yake.

Hapana shaka kwamba ulimwengu wetu umeendelezwa na kukomazwa na teknolojia. Lakini pia ulimwengu uu huu umetishiwa na teknolojia. Teknolojia na maendeleo ni wakala wakubwa wa ongezeko la hali ya joto duniani. Iwapo hali hii huitasitishwa mwanadamu atajikuta katika mazingira ya taabu na dhiki za kumwagamiza kabisa.

Maswali

- a) Kwa nini ulimwengu unajitahidi kuyahifadhi mazingira? (Alama 2)

.....
.....
.....

- b) Eleza matatizo matatu ya kimazingira yanayokabili nchi zilizoendelea (Alama 3)

.....
.....
.....
.....

- c) Kwa Mujibu wa kifungu ulichosoma,eleza hasara ziletwazo na ukataji wa miti.(Alama 4)

.....
.....
.....

.....
.....
.....
d) Taja methali mbili zinazotumia neno lifuatalo (Alama 2)

Mti
.....
.....

e) Mvua kifungu eleza maana ya : (alama 4)

- i. Wakala
- ii. Kawi.....
- iii. Mafuta ya risasi
- iv. Inashamiri

2. MUHTASARI: ALAMA 15

Soma taarifa ifuatayo kisha ujibu maswali.

Chambilecho wahenga, mgaagaa na upwa hali mkavu. Walio na bidii katika jambo fulani mwishowe hufaulu na kufurahia matunda ya bidii zao. Kufaulu huku kwao huwavutia watu wengi kwa sababu wanakuwa kielelezo cha kuigwa na watu hao. Watu wengi waliofaulu katika maisha wana historia ya kufanya bidii na kujitolea kwa udi na uvumba katika majukumu au masomo yao. Ben Carson ni mmoja kati ya watu waliofaulu duniani na kuwa tabibu wa kutajika. Ben alizaliwa katika familia iliyokuwa na changamoto kadhaa. Alipojiunga na shule, alikuwa na matatizo ya kufanya vizuri shuleni. Mara nyingi alikuwa wa mwisho katika mjarabu shuleni. Hata hivyo Ben hakutamauka. Aliamua kutia bidii na kujizatiti katika masomo yake. Baada ya muda, alikuwa bingwa katika masomo yake ambapo baadaye aliibuka kuwa daktari maarufu sana duniani.

Akiwa mwanafunzi katika shule ya upili ya Kagumo, Daktari James Mwangi hakujua kuwa siku moja atakuja kubadilisha maisha ya maelfu ya wanafunzi kutoka katika shule mbalimbali kote nchini kupitia mpango maarufu wa *'Wings to Fly'* unaodhaminiwa kwa kiasi kikubwa na Benki ya Equity. Mradi huu wa mabilioni ya pesa unahusu ufadhili wa wanafunzi werevu hasa kutoka katika familia zisizojiweza. Wanafunzi hawa wamepata nafasi ya kuendeleza masomo yao hadi

katika vyuo vikuu vya humu nchini na pia vya huko ughaibuni. Baadhi ya vyuo hivi ni kama kile cha Harvard, Yale, MIT na vinginevyo maarufu kote duniani. Wanafunzi hawa huweza kupata mafunzo katika taaluma mbalimbali kama vile Utabibu, Uhandisi, Uchumi, Usanii na kadhalika.

Katika mwaka wa 2013, Benki hii ya Equity iliwafaidi takriban wanafunzi 5,000 kutoka katika kila eneo la nchi hii tukufu. Wanafunzi hawa wanalipiwa karo yote kulingana na kiasi kinachohitajika kwa kiwango cha shule husika. Hii ni kwa sababu kuna shule ambazo hutoza karo ya juu hasa zile za kitaifa ikilinganishwa na shule zisizo za kitaifa. Fauka ya hayo, wanafunzi hawa hupewa masurufu itakayowakimu wakati wote wa muhula watakapokuwa wakiendeleana masomo yao. Wanafunzi pia hunufaika na nauli ya kwenda nyumbani mwishoni mwa muhula yao. Iwapo watahitajika kwenda nyumbani wakati wa mapumziko ya katikati ya muhula, benki hii vilevile huwapa nauli.

Benki hii hufanya hivyo ili kuonyesha umuhimu wa wanafunzi kufanya bidii katika masomo yao. Bidii hii inahitajika katika daraja zote za elimu, zikiwemo, shule za msingi na katika shule za upili. Wanafunzi wengi werevu ambao wangepoteza nafasi zao za kuendelea na masomo yao wamenusuriwa na mpango wa benki na kupata nuru ya maisha ya baadaye. Iwapo nchi hii ingekuwa na watu kumi walio na maono kama ya Daktari James Mwangi basi nchi hii ingekuwa imepaa na kuambaa katika elimu na kunawiri katika uchumi. Katika kitengo hiki, tuna msaada kutoka kwa Benki ya Ushirika na pia ile ya Family.

Wakfu wa Jomo Kenyatta Foundation ni mfano mwingine wa watu waliojitolea kuimarisha masomo ya wanafunzi werevu kutoka katika familia zisizojiweza hasa katika shule za upili. Wao pia wamejizatiti kuwalipia wanafunzi hao karo na kuwafadhili katika masomo yao kwa njia nyingine nyingi ili kuhakikisha kuwa azma ya wanafunzi hawa inaafikiwa katika maisha ya baadaye.

Mashirika mengine pia yamejitolea katika kuhakikisha kuwa wanafunzi wanapaa katika maisha yao kwa kukuza masomo yao au talanta za watoto hao. Kampuni za maziwa kama vile Brookside, kampuni ya Milo, watengenezaji soda wa CocaCola na wengine wengi pia wamejizatiti katika kuboresha maisha ya wanafunzi. Kampuni hizi huchangia katika kudhamini michezo baina ya shule za upili kama vile ile ya kitaifa kila mwaka. Michezo hii huhusisha soka, raga, mpira wa nyavu, riadha, magongo na kadhalika. Mashirika haya hukusudia kuhimiza bidii

- g) **Changanua sentensi ifuatayo kwa kutumia jedwali** (alama 3)
Sikumwadhibu kwa sababu alikuwa mgonjwa.

- f) Neno mlevi limetumikaje katika sentensi zifuatazo? (alama 2)

Mlevi alisababisha ugomvi

Mtu mlevi alisababisha ugomvi

- g) Bainisha kishazi huru na kishazi tegemezi katika sentensi hii. (alama 2)

Nitaenda nyumbani ingawa ninaumwa na kichwa

- h) Tunga sentensi sahihi ukitumia hadi kama (alama 2)

- i) Kihusishi cha wakati

.....

- ii) Kihusishi cha mahali (alama 2)

.....

- i) Eleza matumizi ya kwa, ku, ka katika sentensi hizi. (alama 3)

- a) Nitakutaka ufike hapa.

.....

- b) Kachezeni kule nje.

.....

- c) Yule mtaalamu alielezea maana ya utandawazi kwa ufasaha.

.....

j) Ziandike sentensi zifuatazo ukizingatia maagizo. (Alama 2)

i) Chakula kinachoiva vizuri ndicho kinacholiwa (hali ya mazoea)

.....
.....

ii) Timu ile imeshinda . Haikucheza vizuri (Tumia ijapokuwa)

.....
.....

k) Sentensi hizi ni za aina gani? (Alama 2)

i) Mkulima aliyekata rufani atasaidiwa kesho .

.....

ii) Walimu na wazazi wanatengeneza bwani.

.....

l) Andika kinyume cha: (alama 2)

i) Mtweke Bi. Kizee mtungi huu wa maji .

.....

ii) Mama alitandaza zulia kubwa sebuleni .

.....

m) Tumia vitenzi - nya na -ja kutunga sentensi sahihi katika kauli iliyo mabanoni. (alama 2)

i)-nya (tendewa)

.....

ii)-ja(tendeka)

.....

n. Andika kwa msembo halisi (alama 2)

Wanga alisema kuwa alikuwa amepata alama zote katika mtihani wa mwisho wa mwaka

.....
.....
.....

o) Andika kwa wastani halafu kwa ukubwa . (alama 2)

Kibuzi kile kinono kina kiguu kinachouma .

i).....
.....

ii).....
.....

p) Andika kwa wingi .
Kuku yuyu huyu ndiye aliyetaga yai hili . (alama 2)

.....
.....
.....

q) Yakinisha sentensi hii .
Usipolala sana hutapona haraka. (alama 1)

.....

w) Tunga sentensi moja kwa kutumia maneno yafuatayo ili kubainisha maana. (alama 2)

- i) Bana
- ii) pana

.....
.....

ISIMU JAMII ALAMA 10

Soma makala kisha ujibu maswali

(Mdundo wa muziki) kina mama mpo.....! Kina siste nanyi... are you there? Kampuni ya platinum imewaletea mafuta mpya ya silk. Mafuta hayo yana vitamin C, Sunscreen na yana marashi ya kupendeza. Ukiyatumia kwa wiki moja tu, ngozi yako itakua laini na nyororo kama ya kitoto kichanga. Nayo macho ya wote, Waaa! Yatakuwa kwako 24/7. Jinunulie! Jinunulie! Mafuta ya silk. Mafuta ya wanawake wa kisasa.

a. Taja sajili iliyotumiwa hapa. (alama 1)

.....

b. Eleza sifa nne za sajili hii. (alama 4)

.....
.....
.....
.....



BUTERE GIRLS' NATIONAL SCHOOL

MOCK EXAMS 2025



Kenya Certificate of Secondary Education

NAME _____ ADM NO _____ CLASS _____

102/3

KISWAHILI

KARATASI YA 3

FASIHI

MUDA: 2 ½

Kiswahili

Fasihi

MAAGIZO:

1. Jibu maswali manne pekee.
2. Swali la kwanza ni la lazima.
3. Maswali hayo mengine matatu yachaguliwe kutoka sehemu nne zilizobaki; yaani Riwaya, Tamthilia, Hadithi fupi na Ushairi.
4. Usijibu maswali mawili kutoka sehemu moja.

KWA MATUMIZI YA MTAHINI PEKEE

SWALI	UPEO	ALAMA
1	20	
2	20	
3	20	
4	20	
JUMLA	80	

Soma dondoo kisha ujibu maswali yanayofuta ;

Watategemewa na nani maishani? Hiki ndicho kizazi cha kesho au kizazi kilichopotea tayari?

- a) Weka dondoo hili katika muktadha wake. (alama 4)
- b) Tambua toni katika mazungumzo haya. (alama 2)
- c) Onyesha ni vipi kizazi cha leo na cha kesho kilivyopotea. (alama 12)

2. TAMTHILIA:**BEMBEA YA MAISHA – Timothy Arege****ALAMA 20****Jibu swali la i au ii****i) Soma dondoo lifuatalo kisha ujibu maswali yanayofuata:**

...lakini ndio tabia yenu wanawake. Miaka inaposonga kama hivi mnatuona kama... kama... kama... kama vile tambara bovu.

- a) Eleza muktadha wa dondoo hili. (alama 4)
- b) Eleza umuhimu wa msemewa katika kukuza maudhui. (alama 4)
- c) Tambua mbinu nne za kimtindo katika dondoo hili. (alama 4)
- d) Kwa kutoa hoja nne kutoka kwa Tamthilia eleza ni vipi utamaduni ulivyothaminiwa katika jamii hii ya Bembea ya Maisha. (alama 4)
- e) Onyesha jinsi faraja ilivyoalika katika maisha ya msemewa kwa kurejelea tamthilia ya: Bembea ya Maisha. (alama 4)

AU

- (a) Changanua mtindo katika kifungu kifuatacho. (alama 10)

Maskini mke wangu! Kumbe ugonjwa haukumsaza mwaka baada ya mwaka. Umemla bila huruma. Awali niliona kama mchezo. Kumbe ilikuwa kweli! Kauli yake ninaona imesimama. Ni mwele hakika. Laiti ningejua, jana ningeishi tofauti. Silesi zetu za maisha tungezila zilivyokuja kwa furaha. (*Kimya*). Siku hazigandiwala jana hairudi. Sasa jana imebaki kuwa kumbukizi baada ya kusombwa na wakati mfano wa mafuriko msimu wa masika. (*Kimya*). Kwa bahati nzuri bado tupo. Ninaweza kuiachia dunia tabasamu iwe silesi kwa vizazi vijavyo na kila mwenye nia njema. (*Kimya*). Siwezi kuendelea kuishi hivi. Sasa nimekata shauri. Lazima niache njia ya zamani na kuifuata mpya. Maisha mapya. Pombe! (*kama anayeisemea pombe*). Umenichezeshwa kama mwanasesere kwa muda mrefu. Umeninyima fursa ya kuielewa familia yangu. Hapana! Siku zangu za uzeeni lazima nizitumie kumwagalia mke wangu mgonjwa. Lazima nimshukuru kwa vitendo kwa jinsi alivyojitolea kuijenga familia yetu. (*anapunga mkono.*) Kwaheri pombe. Buriani.

- b) Bainisha toni ya dondoo hili. (alama 2)
- c) Fafanua umuhimu wa msemaji wa maneno haya katika kuijenga tamthilia nzima. (alama 8)

i) Soma shairi hili kisha ujibu maswali.

Nilikuomba chakula, nawe kweli kaninyima
Sikuwa hata na hela, kakimbila kwenye **dhima**
Megunduwa ewe Shilla, hunijalingi daima.

Sisahau kisogoni, mnobe ulipokuwa
Makabadhi linombeni, nani kwa wema litowa
Na libasi za mwilini, samani za mtakawa.

Shilla ya shule **sifutu**, lokufanyia hisani
Dafutari na madutu, sare pia likupeni
Linisumbua kuntu, na mie kavumileni

Kozi na nilikupeni, kulipa karo chuoni
Ulinisapa kamani, mnobe nikabakini
Asante punda yani, ni mateke wajamani

Bada ya kazi mwanangu, siku ‘tupa abadani.
Nilisaka msenangu, lodi rafiki moyoni
Ka‘pa kazi wanguwangu, hela nyingi kushikeni

Babayo alifariki, ukiwa bado kiini
Kiacha bila rafiki, hapo hapo pa nyumbani
Nami amiyo kacheke, na nikakuchukueni

Waringa kama tausi, wewe Shilla ni kinyonga
Daraja usilitusi, lokuvusha engaenga
Unapofika ofisini, kumbuka kutojitenga

Maswali

- (a) Lipe shairi hili anwani inayofaa. (alama 1)
(b) Bainisha hisani **tatu** alizofanyiwa nafsi nenewa. (alama 3)

- (c) Tambua nafsi neni katika shairi hili. (alama 1)
- (d) Andika ubeti wa **pili** katika lugha nathari. (alama 3)
- (e) Taja na ueleze mbinu **tatu** alizotumia malenga ili kutosheleza mahitaji yake ya kiarudhi. (alama 3)
- (f) Eleza toni za shairi hili. (alama 1)
- (g) Fafanua sura ya shairi hili. (alama 3)
- (h) Ainisha shairi hili ukizingatia vigezo vifuatavyo: (alama 3)
- (i) Mishororo
 - (ii) Migao/ vipande
 - (iii) Vina
- (i) Eleza maana ya maneno haya kama yalivyotumiwa katika shairi. (alama 2)
- (a) Dhima
 - (b) sifutu

AU

ii) Soma shairi lifuatalo kisha ujibu maswali.

Moyo haukongi:

Haidhuru uwe wa mwanadamu

Au wanyamamwitu.

Japo maji yamyumbishe

Kando ni mwabahari

Kizee utamwona

Kwa nguvu za uchawi wa moyo

Mawimbini akisukwasukwa

Mithili ya jahazi lililochoka

Kwa urefu wa safari:

Ingawa atabamizwa matumbwaweni

Na yake seruni maji kuitwaa

Atang'ang'ana kuidaka japo kwa shida

Na majini kuelea
Kama anayeyatisha kuwa
Bado si haya misuli ipo.

Basi ajabu usione
Paka maziwa kunywa
Katika uzima wake
Au bi kizee kichwa akiyumbisha
Kwa mliowaala
Ama nyama kupania kula
Japo jino la mwisho
Liling'oka juzi.

Moyo haukongi kwa msukumo wa wakati:
Ni misuli inokonga.
Moyo, simba wa wakati.

- a) Hili ni shairi la aina gani? (Alama 2)
b) Eleza muundo wa shairi hili. (Alama 4)
c) Kwa nini mshairi anaeleza kuwa moyo haukongi? (Alama 4)
d) Tambua mishororo baki kwenye shairi hili. (Alama 2)
e) Eleza mbinu mbili za idhini ya mshairi kwa kurejelea shairi hili. (Alama 2)
f) Eleza toni ya shairi hili. (Alama 2)
g) Andika ubeti wa tatu kwa lugha tutumbi. (Alama 4)

4. HADITHI FUPI: Mapambazuko ya Machweo Na Hadithi Nyingine na D.W. Lutoma na Phibbian

Muthama

ALAMA 20

Jibu swali moja

i) Mzimu wa Kipwerere!-Yussuf Shoka Hamad

Soma dondoo kisha ujibu maswali yanayofuata.

“...Akainama chini kwenye tendeguu moja la kitanda cha besera.Akachukua kibatari cha kiberiti ili awashe taa.Mimi,nikiwa mle mvunguni.sasa kwa hakika nilishamjua shetani wa mzimu ule ni nani.Kumbe hakuwa shetani wala Kipwerere!”

- a)Yaweke maneno haya katika muktadha wake. (alama 4)
b)Fafanua mbinu za kimtindo katika dondoo hili. (alama 4)
c)Onyesha umuhimu wa mandhari katika dondoo hili. (alama 4)
d)Wanakijiji waliuogopa mzimu wa Kipwerere kiasi cha kuuabudu na kutoufanyia mzaha.
Thibitisha kauli hii (alama 8)

AU

ii) ***Msiba wa Kujitakia - D.W .Lutomia***

“Wetu ni wetu ,hata akiwa mbaya ...ni wetu.hatuna budi kuchagua yeye .lisilobudi hubidi.”

- (a)Eleza muktadha wa dondoo hili. (alama 4)
(b)Fafanua vipengele vya kimtindo katika dondoo hii. (alama 4)
(c)Hiari ya maamuzi ya wahusika mbalimbali yamewaitea madhila anuwai.jadili.(alama 12)

5. FASIHI SIMULIZI ALAMA 20

Chagua swali moja kati ya haya

1.Soma utungo ufuatao kisha ujibu maswali

Heri ujue mapema
Nasaba yetu haina woga
Woga haumei kwetu, humea kwa kina mamako.
Tulichinja jogoo na fahali ili uwe mwanaume.

Ah! Kisu cha ngariba ni kikali ajabu.
Iwapo utatikisa kichwacho.
Uhamie kwa wasiotahiri,
Ama tukwite njeku.

Mpwangu kumbuka hili,
Wanaume wa mlango wetu
Si waoga wa kisu
Wao hukatwa mchana hadi usiku
Wala hawalalamiki.

Siku nilipokatwa
Nilisimama tisti
Nikacheka ngariba kwa tashtiti
Halikunitoka chozi.

Iwapo utapepesa kope
Wasichana wa kwetu na wa mbali
Wote watakucheka
Ubaki ukinuna.

Sembe umepokea
Na supu ya makongoro ukabugia
Sema unachotaka
Usije kunitia aibu

Maswali;

- (a) Taja na uthibitisha shughuli zozote za kiuchumi za jamii ya wimbo huu (alama 4)
- (b) Ni nani mwimbaji wa wimbo huu na anawambia nani? (alama 2)
- (c) Huu ni wimbo wa aina gani? Thibitisha (alama 2)
- (d) Mwimbaji wa wimbo huu ana taasubi ya kiume. Thibitisha kauli hii. (alama 2)
- (e) Eleza kwa hoja sita wajibu wa nyimbo katika jamii (alama 6)
- (f) Ijapokuwa nyimbo ni nzuri, zina ubaya wake. Thibitisha kauli hii kwa hoja nne. (alama 4)

AU

2. Soma yafuatayo kisha ujibu maswali

...Niaje wazungu wanaweza kutunza vitu vikajaa kwenye friji? Kwani tamaa yao huwa wapi?
Yaani nimeweka soda mbili tu kwenye friji lakini akili haitulii hadi nizinywe. Siwezi kulala chumba kimoja na chakula.. Niko sebuleni nazunguka tu kama koo atafutaye pa kutagia yai. Najaribu kuwaza vitu vingine lakini wapi! Akili inianiambia tu, "My friend, kunywa soda!"

- a) Bainisha kipera cha utungo huu (alama2)
- b) Utanzu wa kipera hiki huweza kuchukua nafasi muhimu katika fasihi simulizi. Thibitisha kwa kurejelea hoja zozote sita (alama6)
- c) Ufanisi wa uwasilishaji wa utanzu huu unategemea fanani. Tetea kauli hii. (alama6)
- d) Ni changamoto zipi zinaweza kumkabili mwanafasihi mtafiti nyanjani? (alama6)



BUTEREGIRLS'NATIONALSCHOOL MOCK EXAMS 2025



Kenya Certificate of Secondary Education

NAME _____ ADM NO _____ CLASS _____

121/1
MATHEMATICS PAPER 1

TIME: 2 HOURS 30 MINUTES

INSTRUCTIONS TO CANDIDATES:

- Write your **name**, **class** and **admission number** in the spaces provided.
- The paper contains **two** sections. Section I and Section II.
- Answer **ALL** the questions in section I and any **five** questions in section II.
- Answers and working **must** be written on the question paper in the spaces provided below each question.
- Show all steps in your calculations below each question.
- Marks may be given for correct working even if the answer is wrong.
- Non programmable silent electronic calculators and KNEC mathematical table may be used, except where stated otherwise.

FOR EXAMINERS USE ONLY

SECTION I

Question	1	2	3	4	5	6	7	8	9	10	11	12	13	14	15	16	TOTAL
Marks																	

SECTION II

Question	17	18	19	20	21	22	23	24	TOTAL
Marks									

GRAND TOTAL

SECTION 1 50 MARKS

Answer all questions in this section

1. Evaluate the following

(3 marks)

$$\frac{8^{1/2} - 6^{2/3} \div 4/9}{2/5 \text{ of } 6 \frac{1}{4} + 1^{1/4}}$$

2. Simplify

(3 marks)

$$\left(\frac{27}{125}\right)^{-2/3} \times \left(\frac{16}{81}\right)^{1/4}$$

3. In a covid 19 vaccination centre teachers may receive their jobs from either of the two doctors stationed at the two tents. On an average one doctor takes 2 minutes while the other doctor takes 3 minutes to serve one teacher. If the two doctors start to serve the teachers at the same time, find the shortest time it takes to vaccinate a total of 300 teachers. (3 marks)

4. Simplify the expression

(3 marks)

$$\frac{6a^2 + ab - 2b^2}{4a^2 - b^2}$$

5. Solve for ϑ if $\sin (2 \vartheta - 50^\circ) = \cos (\vartheta + 10^\circ)$ (3 marks)

6. The velocity V m/s of a particle projected into space is given by the formula $V = 5t^2 - 2t + 9$ where t is the time in seconds elapsed since projection. Determine the acceleration of the particle when $t = 4$ seconds (3 marks)

7. The interior angles of a heptagon are $(2y + 35)^\circ$, 100° , 135° , 150° , 125° , $(3y + 25)^\circ$ and $(2y + 20)^\circ$. Find the value of y . (3 marks)

8. Two similar cylinders have diameter of 14cm and 42cm. If the larger cylinder has a volume of $12,474\text{cm}^3$. find the volume of the smaller cylinder (3 marks)

9. The figure below shows a circle centre O, PQRS is a cyclic quadrilateral and QOS is a straight line. Angle PRQ is 70°

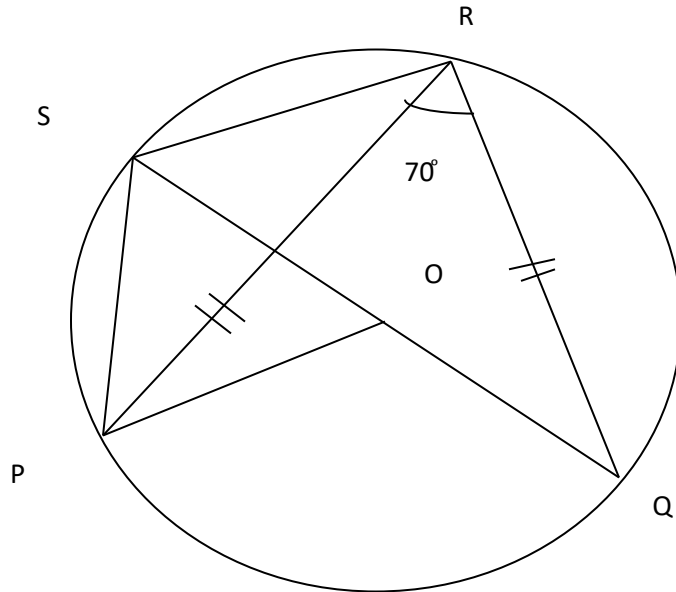

Giving reasons for your answer, find the size of

- a) Angle POQ (1 mark)
- b) Angle PRS (2 marks)

10. Solve for x and state the integral values (4 marks)
- $$23 - 2x > x + 2 \geq -\frac{1}{4}x - 3$$

11. Given that $\vec{a} = 3\mathbf{i} - 2\mathbf{j} + 3\mathbf{k}$ and $\mathbf{b} = 2\mathbf{i} - 4\mathbf{j} - 3\mathbf{k}$ where \mathbf{i} , \mathbf{j} and \mathbf{k} are unit vectors. Find $\frac{1}{2} \vec{a} + 2\mathbf{b}$ (3 marks)

12. Use the exchange rates below to answer this question

	Buying (Kshs)	Selling (Kshs)
1 US dollar (\$)	105.00	105.40
1 UK Sterling Pound (£)	145.20	145.75

A tourist arrived in Kenya from Britain with 7, 800 UK £. He converted the whole amount of money to Kenya shillings. While in Kenya, he spent 70% of his money and changed the rest to US \$. Calculate the amount of money to the nearest dollar that he received. (3 marks)

13. Construct triangle ABC in which BC=6cm, AB=4.5cm and angle ABC = 135°. Drop a perpendicular from point B to line AC and determine the shortest distance from point B to line AC (4 marks)

14. Use tables of cubes, cube roots and reciprocals to find the value of: (3 marks)

$$\frac{4}{\left[8.63\right]^3} + \left[\frac{5}{34.46}\right]^{1/3}$$

15. A juice seller blends three types of juices P,Q and R in the ratios P:Q =3:4 and Q:R = 1:2. The blend contains 16.8 litres of R.

a) Find the ratio P: Q: R (1 mark)

b) Find the required capacity of P in the blend

(3 marks)

15. A hawker bought 1948 sweets on the first day and sold 570 sweets on the same day. On the second day he sold 204 sweets more than the first day. On the third day he added 650 sweets to his stock. He sold all sweets on the same day at the price of sh. 5 each. Calculate the amount of money he received on the third day. (3 marks)

SECTION II 50 MARKS

Attempt any five questions only in this section

16. a) A triangle with vertices A(-4, 2) B((-6,6) and C(-6,2) is enlarged by a scale factor -1 and center (-2 ,6) to produce triangle A'B'C'. Draw triangle ABC and A'B'C' and state its coordinates (4 marks)

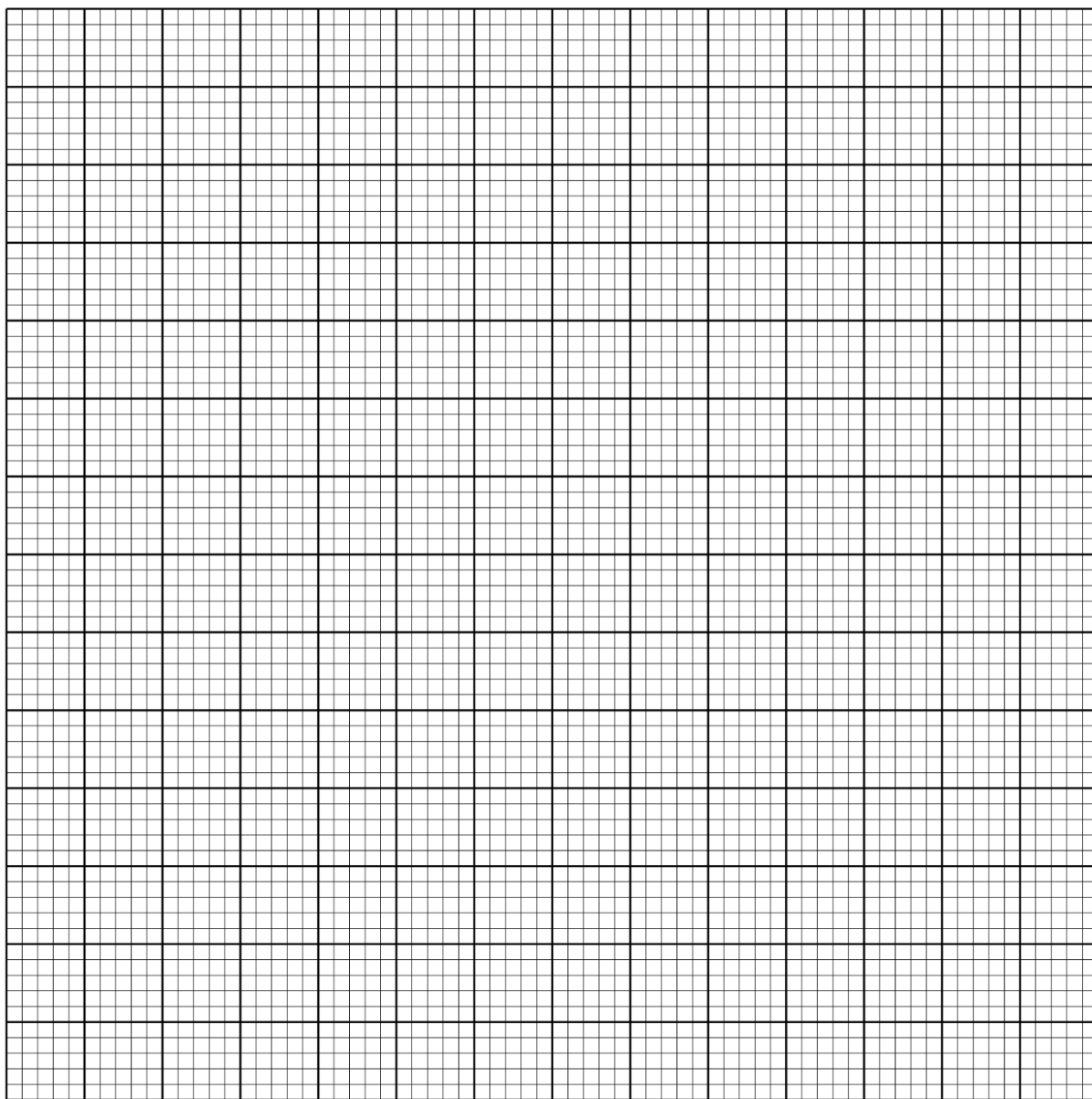

b) Triangle A'B'C' is then reflected in the line $y = x$ to give triangle A''B''C''. Draw A''B''C'' and state its coordinates. (3 marks)

c) If triangle A''B''C'' is mapped on to A'''B'''C''' whose coordinates are A''' (0, -2), B''' (4, -4) and C''' (0, -4) by rotation. Find the center and angle of rotation (3 marks)

18. The table below shows heights of 50 students

Height (cm)	150- 154	155-159	160-164	165-169	170-174	175-179
Number of students	5	13	12	x	7	3

a) Determine the value of X (1 mark)

b) Calculate the mean height

(4 marks)

d) i) On the grid provided draw a histogram to represent the above information. Use a scale of 1cm to represent 5 students and 2 cm to represent 5 cm (2 marks)

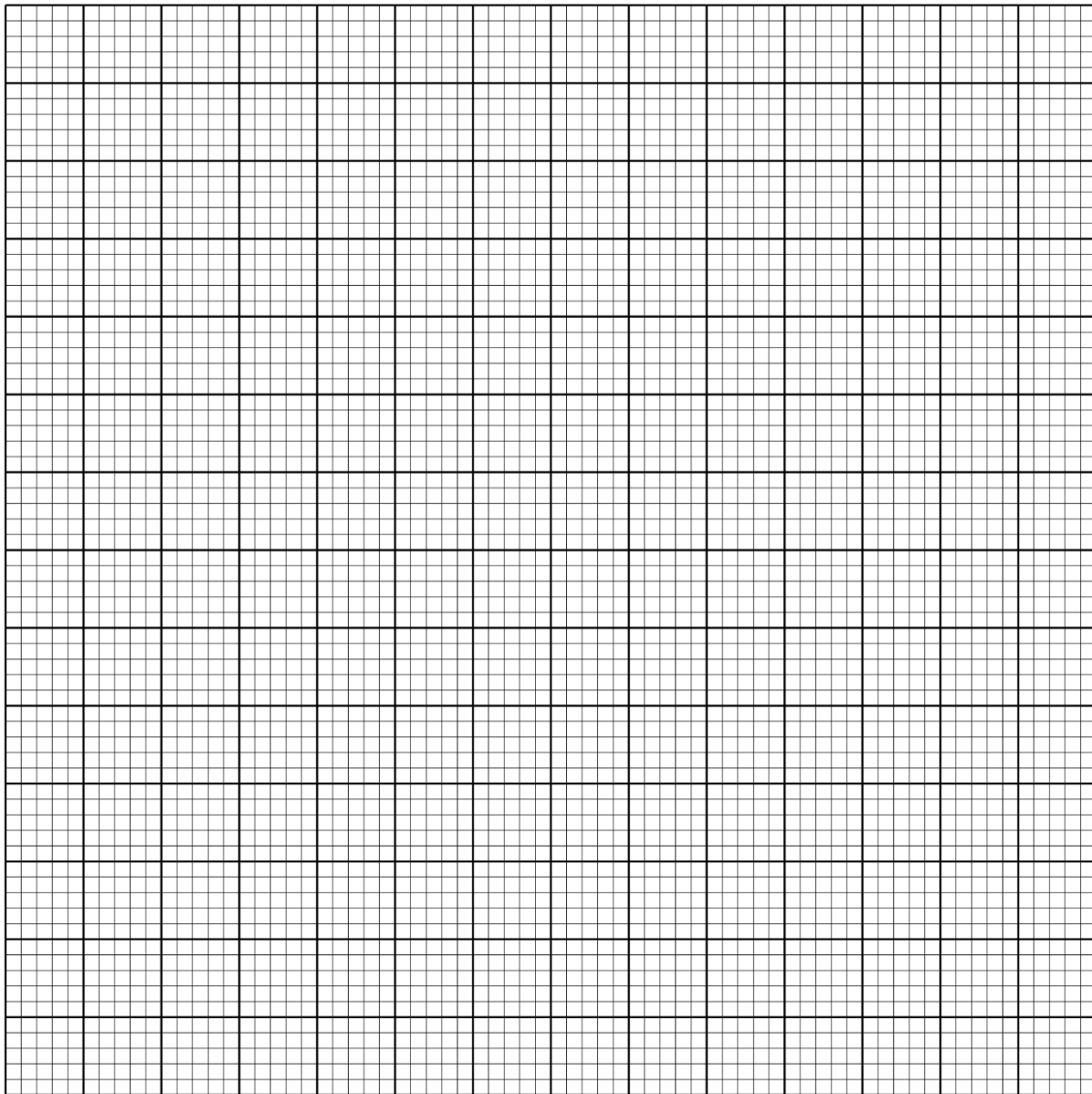

ii) On the histogram, draw a vertical line to show where the median mark lies. (3 marks)

19. The figure below shows a test tube used to store laboratory reagents during a research study. One of the study reagents was filled into the test tube up to 80% full.

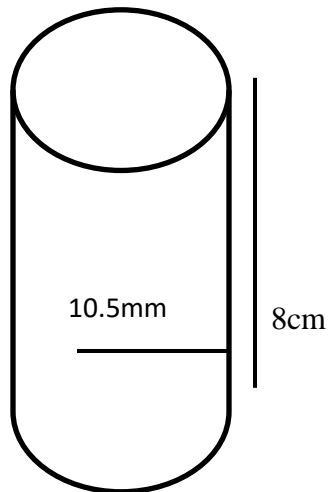

Calculate:

a) The volume of the reagent in the test tube

(3 marks)

b) The height of the reagent in the test tube

(3 marks)

c) The total surface area of the tube in contact with the reagent (4 marks)

20. A bus left Mombasa and travelled towards Nairobi at an average speed of 60km/hr. After 2hrs and 30minutes, a car left Mombasa to Nairobi and travelled along the same road at an average speed of 100km/hr. if the distance between Mombasa and Nairobi is 500km.

a) Determine:

(i) The distance of the bus from Nairobi when the car took off. (2 marks)

(ii) The distance the car travelled to catch up with the bus (4 marks)

b) Immediately the car caught with the bus the car stopped for 25 minutes. Find the new average speed at which the car travelled in order to reach Nairobi at the same time as the bus. (4 marks)

21. The velocity of a particle after t seconds is given by $V = t^2 - 2t + 4$.

a) Use the mid ordinate rule with six strips to estimate the displacement of the particle between $t = 1$ and $t = 13$ (3 marks)

b) Determine:

i) The exact area of the particle between $t = 1$ and $t = 13$ (3 marks)

ii) Acceleration of the particle at $t = 4$ (3 marks)

c) Calculate the percentage error arising from the estimated area in (a) above (2 marks)

22. A shopkeeper planned to buy some fridges from a sum of 1.8 million shillings. Before she could buy the fridges, the price per unit was reduced by sh. 4,000. As a result, she was able to buy five fridges the same amount of money as originally planned.

a) Determine the number of fridges that the shopkeeper bought (6 marks)

b) If two of the fridges purchased got damaged while in store and rest were sold making a profit of 20%, calculate her profit per fridge (4 marks)

23. The equation of a line L_1 is $3y - 2x = 10$

a) Find in form of $y = mx + c$ where m and c are constants

i) The equation of line L_2 passing through point $N (-5, 2)$ and parallel to L_1 (2 marks)

ii) The equation of L_3 perpendicular to L_2 at $M (1, -8)$ (3 marks)

b) Find the angle of inclination of the line L_2 with the horizontal (2 marks)

c) Find the magnitude of MN

(3 marks)

24. The diagram below shows a garden in the shape of a quadrilateral PQRS in which $PQ = SR = 120\text{m}$, $QR = 45\text{m}$, $\angle PQR = \angle SPQ = 90^\circ$ and $\angle QRS = 135^\circ$

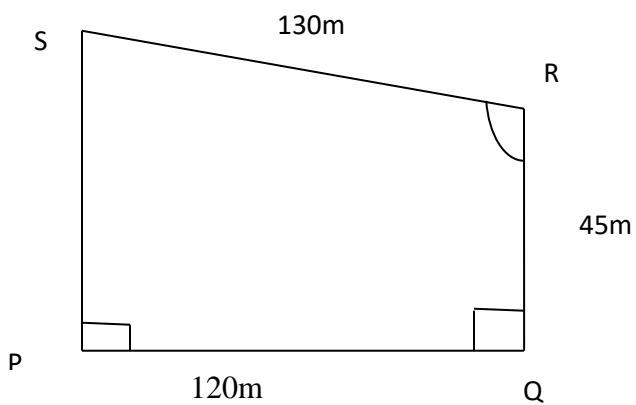

a) Calculate to 1 decimal place:

i) The size of angle QPR

(3 marks)

ii) The length PS

(4 marks)

b) Calculate the area of the garden in hectares, correct to 3 decimal places

(3 marks)



BUTEREGIRLS'NATIONALSCHOOL

MOCK EXAMS 2025



Kenya Certificate of Secondary Education

NAME _____ ADM NO _____ CLASS _____

121/2
MATHEMATICS
PAPER 2

TIME: 2 HOURS 30 MINUTES

INSTRUCTIONS TO CANDIDATES:

- Write your **name**, **class** and **admission number** in the spaces provided.
- The paper contains **two** sections. Section I and Section II.
- Answer **ALL** the questions in section I and any **five** questions in section II.
- Answers and working **must** be written on the question paper in the spaces provided below each question.
- Show all steps in your calculations below each question.
- Marks may be given for correct working even if the answer is wrong.
- Non programmable silent electronic calculators and KNEC mathematical table may be used, except where stated otherwise.

SECTION I

Question	1	2	3	4	5	6	7	8	9	10	11	12	13	14	15	16	TOTAL
Marks																	

SECTION II

Question	17	18	19	20	21	22	23	24	TOTAL
Marks									

GRAND TOTAL

SECTION 1 50 MKS

Answer all questions in this section

1. Use logarithms to evaluate.

(4 marks)

$$\left[\frac{415.3 \times 0.0152}{\sin 75^\circ} \right]^{1/3}$$

2. The base and perpendicular height of a triangle measured to the nearest centimeter are 12cm and 8cm respectively. Find the absolute error in calculating area of the triangle (3 marks)

3. a) Expand $(3 + \frac{2}{x})^5$ up to the x^4

(1 mark)

b) Hence estimate the value of $(3.5)^5$ to 4 s.f

(2 marks)

4. Find the radius and centre of the circle whose equation is $3x^2 + 3y^2 - 12x + 18y = 9$ (3 marks)

5. An aero plane leaves town A (40° N , 155° W) for town B (40° N, 25° E) using the shortest route at a speed of 300 knots. Calculate the time it takes to travel from A to B (3 marks)

6. The third term and the sixth term of a geometric series are $3\frac{1}{3}$ and $11\frac{1}{4}$ respectively.

Calculate the:

a) Common ratio (2 marks)

b) First term (1 mark)

7. Two taps A and B can fill a water bath in 8 minutes and 10 minutes respectively. Tap A is opened for 2 minutes then closed. Tap B is later opened for one minute then closed. How long will the two taps take running together to fill the remaining part of the water bath? (3 marks)

8. After t seconds, a particle moving along a straight line has a velocity of the v m/s and an acceleration of $(5 - 2t)$ m/s². If the initial velocity was 2m/s, determine the velocity of the particle at the beginning of the third second (3 marks)

9. A quantity P is partly constant and partly varies inversely as square of t . $P = 6$ when $t = 6$ and $P = 18$ when $t = 3$. Find t when $P = 11$. (3 marks)

10. A mobile phone can be purchased in cash ksh. 30,000 or by paying ksh. 1,750 for 24 months. Calculate the rate of interest charged on instalment buying. Giving your answer correct to 2 decimal places (3 marks)
11. Solve for x in $3\log_3 x + 4 = 24$ (3 marks)
12. Solve for x in the equation $6 \sin^2 x - \cos x - 5 = 0$ for $0^\circ \leq x \leq 360$ (3 marks)
13. Two brands of tea costing sh. 160 and 140 per kilogram respectively are mixed in the ration 2:3 by mass. The mixture is sold at sh. 240 per kilogram. Find the percentage profit made. (3 marks)
14. Triangle A'B'C' is the image of triangle ABC under transformation represented by the matrix $\begin{bmatrix} 3 & 1 \\ 5 & 4 \end{bmatrix}$

If the area of triangle A'B'C' is 140cm^2 , find the area of triangle ABC

(3 marks)

15. Given that $PR = 2\text{cm}$, $PN = 12\text{cm}$ and $PM = 3\text{cm}$. Find the length of:

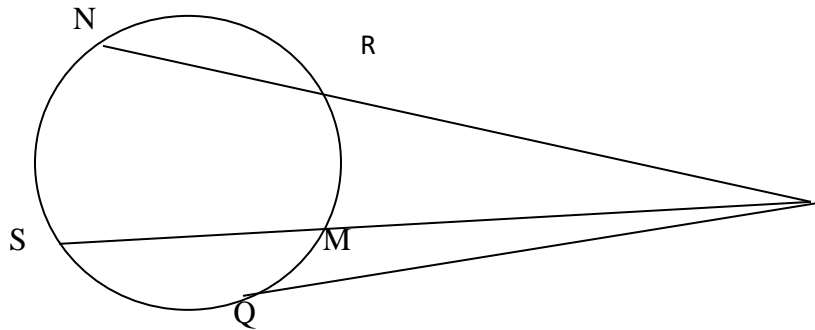

i) PS

(2 marks)

ii) PQ

(1 mark)

16. Given that $\tan x = \frac{1}{\sqrt{3}}$ find the value of $\tan x + \cos x$

(3 marks)

SECTION II 50MARKS

Answer any five questions only in this section

17. In a science class $\frac{2}{3}$ of the class are boys and the rest are girls. 80% of the boys and 90% of the girls are right handed. The probability that the right handed student will break a test tube in any session is $\frac{1}{10}$ and that for the left handed student is $\frac{3}{10}$ regardless of whether boy or girl.

a) Draw a tree diagram to represent this information (2 marks)

b) Using the tree diagram drawn, find the probability that:

i) A student chosen at random from the class is left handed (2 marks)

ii) A test tube is broken by a left handed student (2 marks)

iii) A test tube is broken by a right handed student (2 marks)

iv) A test tube is not broken in any session (2 marks)

18. In a triangle ABC, E is the midpoint of BC, D is a point on AC such that AD: DC = 3:2 and F is the point of intersection of AE and BD. Vectors $AB = \mathbf{b}$ and $AC = \mathbf{c}$

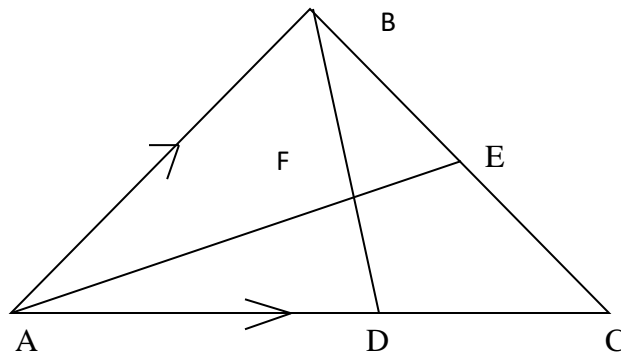

a) Express the following vectors in terms of \vec{b} and \vec{c} only.

i) \vec{AE}

(2 marks)

ii) \vec{BD}

(1 mark)

b) By expressing vectors \vec{BF} in two ways, find the ratio $BF:FD$ given that $\vec{BF} = h\vec{BD}$ and $\vec{AF} = t\vec{AE}$ where h and t are constants

(5 marks)

c) Hence find vector \vec{BF} in terms of \vec{b} and \vec{c} only

(2 marks)

19. A plane S flies from a point P (40°N , 45°W) to a point Q (35°N , 45°W) and then to another point

T (35°N, 135°E).

a) Given that the radius of the earth is 6370km find the distance from P to Q in km. Take $\pi = \frac{22}{7}$ (2 marks)

b) Find in nm

i) The shortest distance between Q and T

(2 marks)

ii) The longest distance between Q and T (to the nearest tens)

(2 marks)

c) Find the difference in time taken when S flies along the shortest and longest routes if its speed is 420 knots (4 marks)

20. The marks obtained by 50 students in an examination were recorded in the table below

Marks	0-9	10-19	20-29	30-39	40-49	50-59	60-69	70-79
Number of student	3	6	10	12	9	5	3	2

Using 44.5 as the assumed mean, calculate

i) The actual mean mark

(4 marks)

ii) The standard deviation to 2 decimal place

(3 marks)

iii) The quartile deviation

(3 marks)

21. Given that $y = 2 \sin 2x$ and $y = 3 \cos (x+45^\circ)$

a) Complete the table below

(2 marks)

X	0°	20°	40°	60°	80°	100°	120°	140°	160°	180°
2sin 2x	0		1.97		0.68	-0.68	-1.73		-1.28	0
3 cos (x+ 45°)	2.12	1.27		-0.78		-2.46			-2.72	-2.12

b) Use the data to draw the graph of $y = 2 \sin 2x$ and $y = 3 \cos (x+45^\circ)$ for $0^\circ \leq x \leq 180^\circ$ on the same axis on the grid provided below (5 marks)

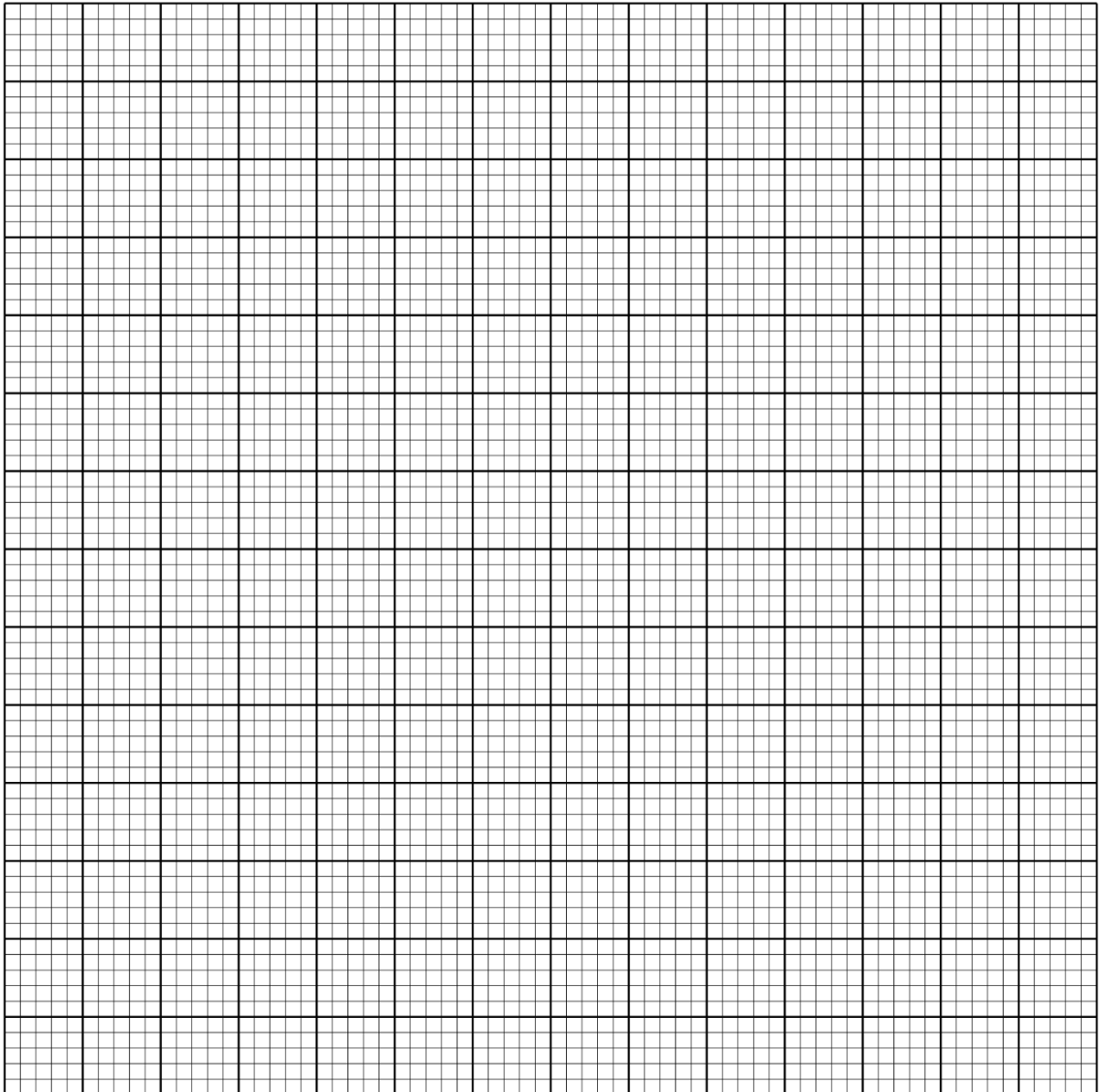

c) State the amplitude and period of each curve

(2 marks)

d) Use the graph to solve the equation $2 \sin 2x - 3 \cos (x+45^\circ) = 0$ for $0^\circ \leq x \leq 180^\circ$ (1 mark)

22. VABC is a pyramid standing on an equilateral triangular base ABC whose sides are 6cm.
VO is the perpendicular height. $VA = VB = VC = 15\text{cm}$.

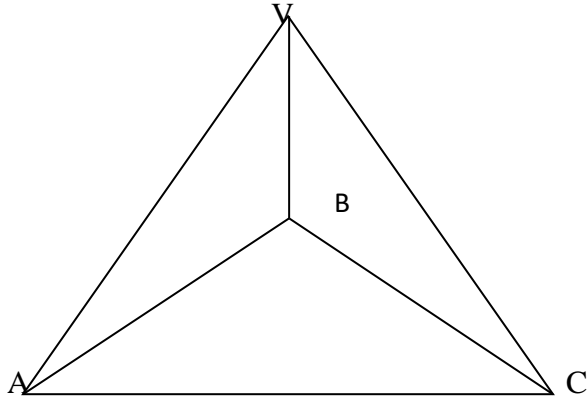

Calculate to 2 d.p

a) Height VO

(3 marks)

b) The inclination of VAB to ABC

(2 marks)

c) The inclination of VB to ABC

(3 marks)

d) The volume of the pyramid

(2 marks)

23. A small scale farmer wishes to buy some sheep and goat for rearing. Sheep cost sh 400 and goat cost sh. 300. The farmer has enough space for only 20 animals and may spend at most sh 6,800.

The number of goats should not exceed twice the number of sheep.

- a) By letting x and y to represent the number of sheep and goats he can buy respectively, write down all inequalities from the above information (4 marks)

- b) Represent the inequalities on the grid provided (4 marks)

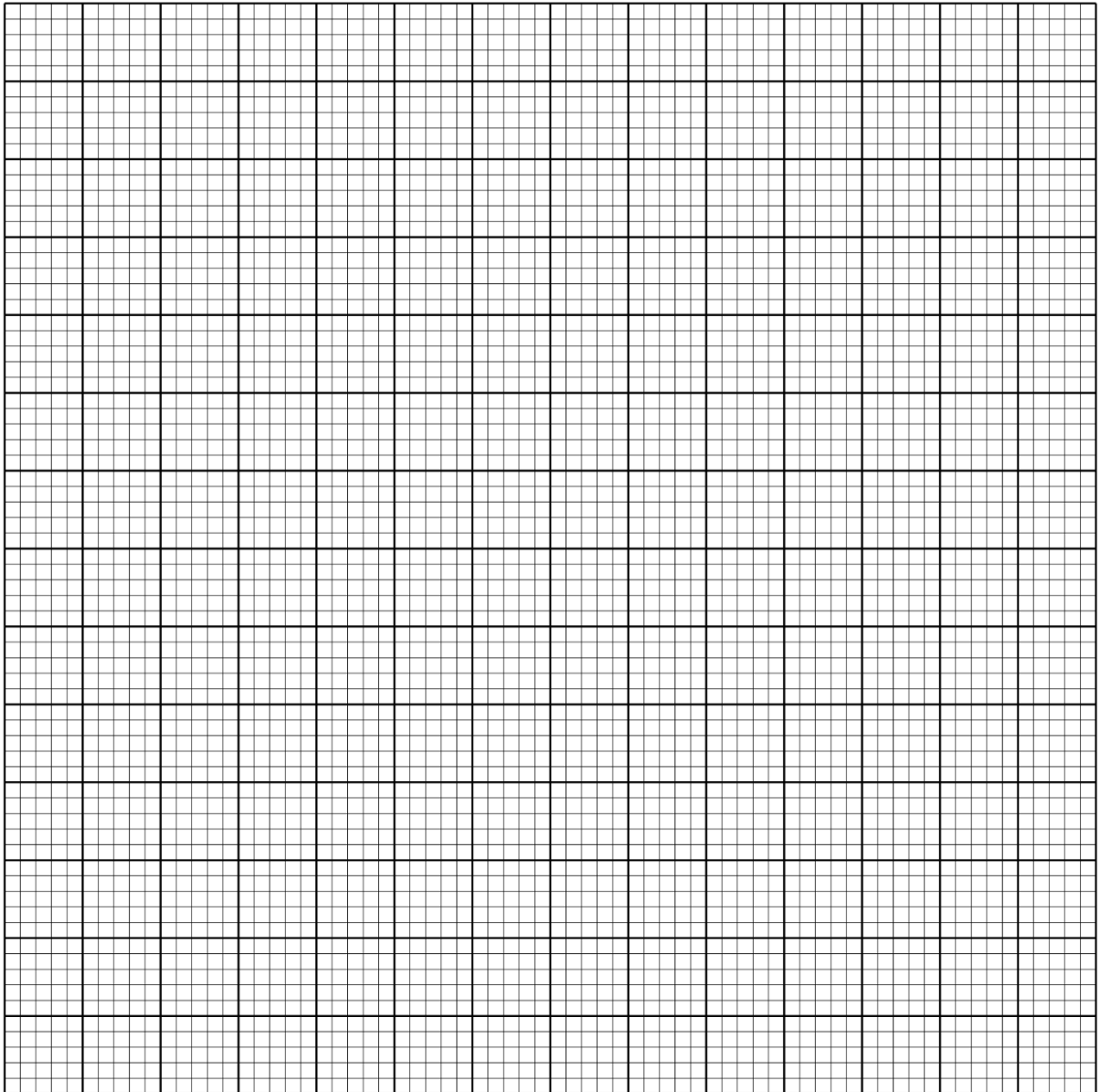

- c) From your graph, find the maximum number of animals he can buy at the lowest cost (2 marks)

24. The following table shows the rate at which income tax was charged during a certain year.

Monthly taxable income in Ksh.	Tax rate %
0 – 9860	10
9861 – 19720	15
19721 – 29580	20
29581 – 39440	25
39441 – 49300	30
49301 – 59160	35
Over 59160	40

A civil servant earns a basic salary of ksh. 35750 and a monthly house allowance of sh.12,500. The civil servant is entitled to a person relief of sh. 1,062 per month. Calculate:

a) Taxable income (2 marks)

b) Calculate his net monthly tax (5 marks)

c) Apart from the salary the following deduction are also made from his monthly income.

WCPS at 2% of the basic salary

Loan repayment Ksh. 1,325

NHIF Ksh. 480

Calculate his net monthly earning (3 marks)



BUTERE GIRLS' NATIONAL SCHOOL

MOCK EXAMS 2025



Kenya Certificate of Secondary Education

NAME..... INDEX NO.:.....

STREAM: ADM NO:

DATE:

PHYSICS

Paper 232/1

(THEORY)

Time: 2 Hours

INSTRUCTIONS TO CANDIDATES:-

- Write your **Name, Index number, Admission number** and **school** in the spaces provided above.
- This paper consists of **two** sections; **A** and **B**
- Answer **all** the questions in section **A** and **B** in the spaces provided
- All working **must** be clearly shown.
- Mathematical tables and electronic calculators may be used
- Take the earth's gravitational field strength $g = 10 \text{ m/s}^2$.

For Examiner's Use Only:

SECTION	QUESTION	TOTAL SCORE	CANDIDATES SCORE
A	1 - 11	25	
B	12	11	
	13	12	
	14	12	
	15	10	
	16	10	
TOTAL		80	

SECTION A (25 MARKS)

Answer all questions in this section in the spaces provided.

1. The figure below shows part of scales of a vernier caliper with a negative error of 0.04cm. It was used to measure the length of a wooden block whose actual length is 7.57cm.

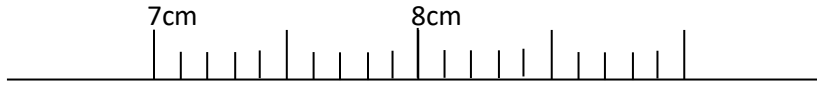

Insert the vernier scale to show how the reading was.

(3mks)

2.
a) The figure below shows two pins of the same mass and both pressed into a soft board by equal amount of force.

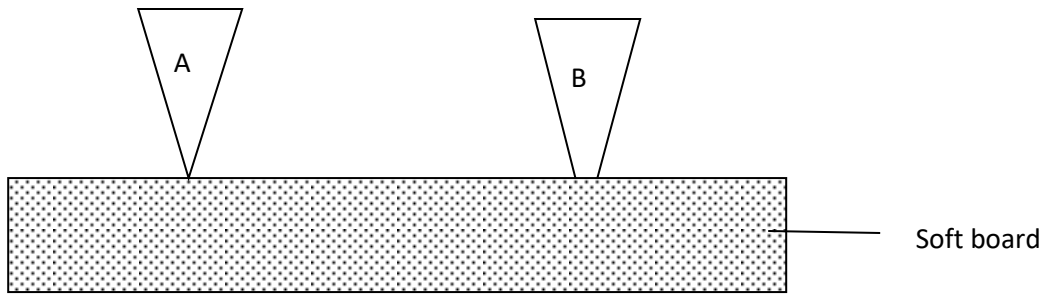

State and explain which pin penetrates the least into the soft board.

(2mks)

.....
.....
.....

- b) The figure below shows a uniform manometer that is closed at one end.

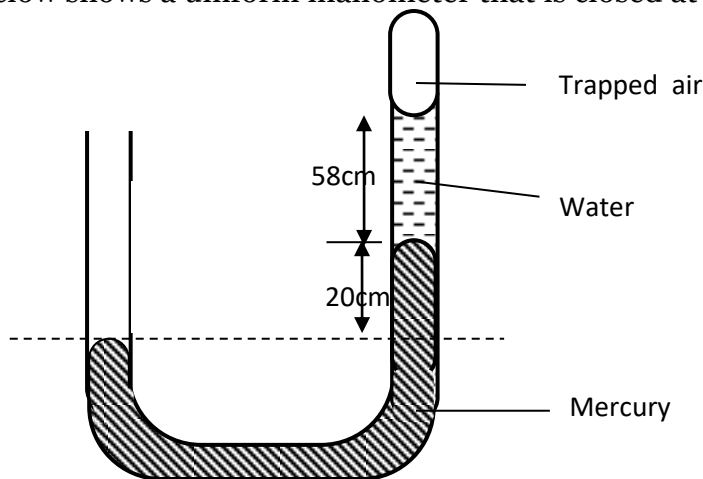

Determine the pressure of the trapped air. (Take atmospheric pressure as 75cmHg, density of mercury = 13600kg/m³ and density of water = 1000 kg/m³) (3mks)

3. The displacement S of a body at time t moving with acceleration a is given by $S = ut + \frac{1}{2}at^2$. State the condition for this equation to apply. (2mks)

.....
.....
.....

4. The figure below shows a sketch of a velocity-time graph for a body falling through a liquid.

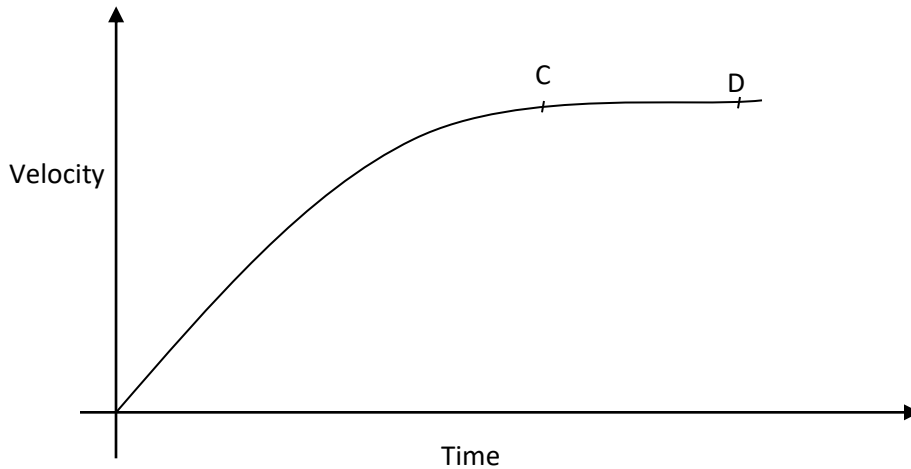

Explain the motion between C and D. (2mks)

.....
.....
.....

5. Using the kinetic theory of gases, explain how an increase in temperature causes increase in pressure of an enclosed gas. (2mks)

.....
.....
.....
.....

6. A driplless candle is lit and placed on a level bench as shown.

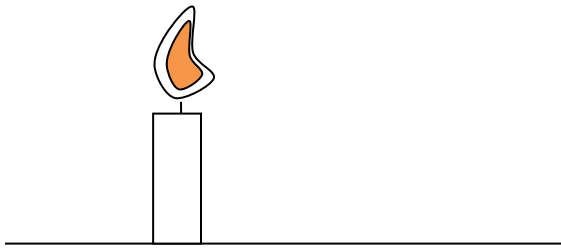

State and explain the changes in stability of the candle as it continues to burn. (2mks)

.....

.....

.....

7. Give a reason why diffusion is an evidence that matter is made up of tiny particles. (1mk)

.....

.....

8. Explain the cause of surface tension on the surface of a liquid. (2mks)

.....

.....

.....

9. A metal block is weighed in air and then in paraffin and water as shown in the Figure below.

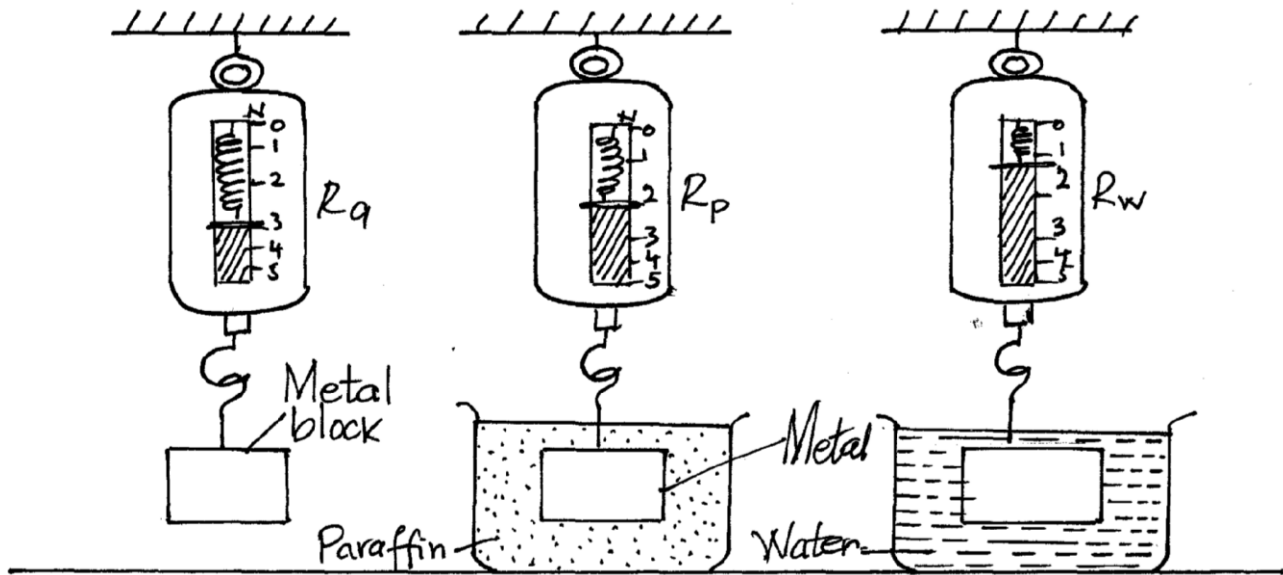

Calculate the density of paraffin given that the density of water is 1000kg/m^3 .
 (Take $g = 10\text{ m/s}^2$)

(3mks)

10. The figure below shows two sheets of paper tolled into tubes. one has holes on it.



A stream of air is blown into each tube as shown. State with reason the tube that collapses.

(2mks)

.....

.....

.....

11. Differentiate between conduction and convection modes of heat transfer in terms of molecules.

(1mk)

.....

.....

SECTION B (55 MARKS)

Answer all questions in this section in the spaces provided.

12.
 a) A form Two student wanted to carry out an experiment to verify Hooke’s law. the student assembled the apparatus as shown.

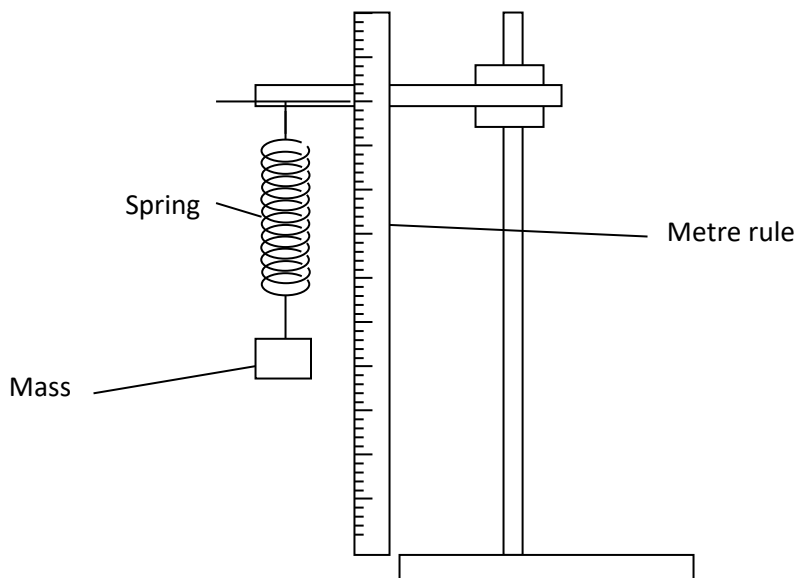

If the student had access to several other masses;

- i.State what was missing in the set up. (1mk)
.....
- ii.Outline how the extension of the above spring is determined. (3mks)
.....
.....
.....
- iii.Other than extension of the spring, state one other measurement that should be determined. (1mk)
.....
- iv.Considering the measurements above, describe how the above set up can be used to verify Hooke's law. (3mks)

b) Three identical springs are joined together as shown below to support a mass of 150g.

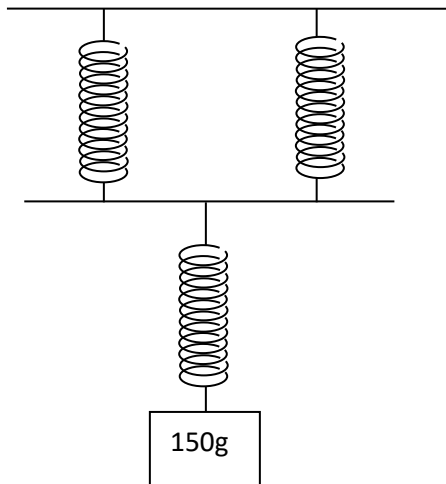

Assuming that the springs have negligible weight and if the total weight of the above set up is 3cm, Determine the spring constant of one spring used in the set up. (3mks)

13. The diagram below shows a wheelbarrow used to raise a 90kg sack of potatoes. The wheelbarrow has a mass of 20kg.

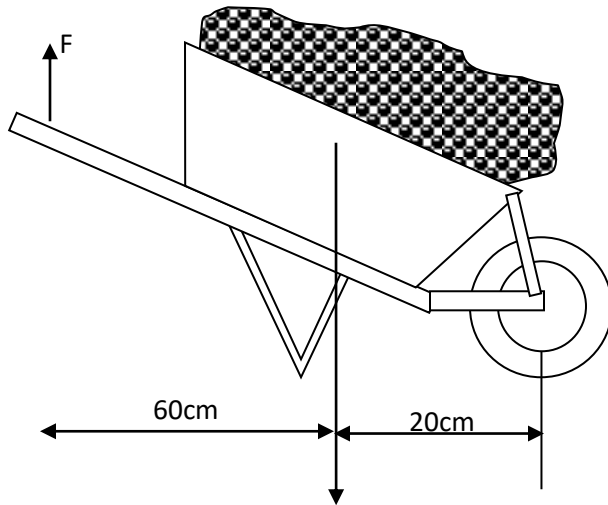

- a) Using the principle of moments, determine the effort that need to be applied at F in order to lift the load. (3mks)
- b) What is the velocity ratio of the wheelbarrow? (3mks)
- c) Determine the mechanical advantage of this machine. (2mks)
- d) Determine the efficiency of the machine. (3mks)
- e) Why is the efficiency of this particular machine less than 100%? (1mk)

14.

a) The diagram below shows a set up that is used in determining the upper fixed point of a thermometer.

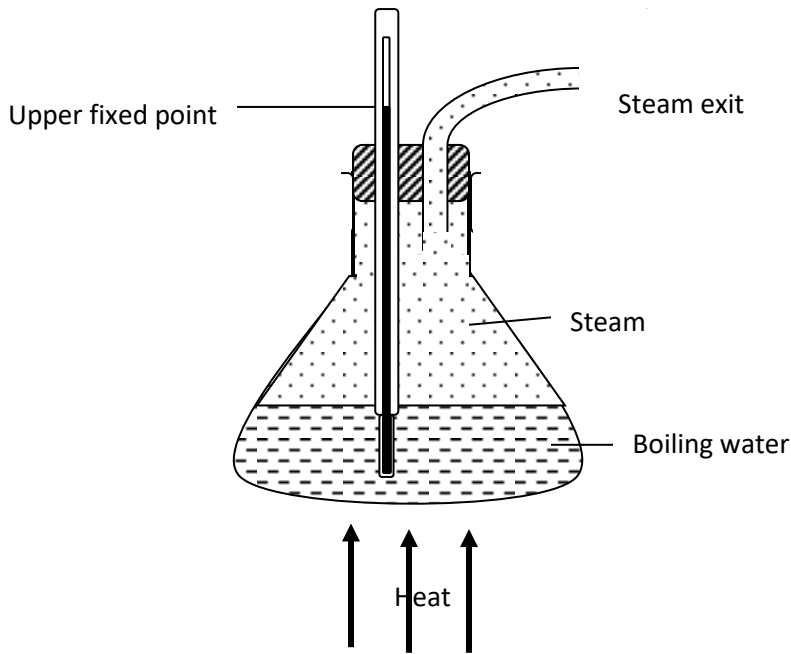

i. Identify the mistake in the set up. (1mk)

.....

ii. Explain how the mistake would affect the value obtained as the upper fixed point. (2mks)

(2mks)

.....

.....

.....

iii. What is the purpose of the steam exit. (1mk)

(1mk)

.....

.....

b) When marking the fixed points of a thermometer, it is observed that at 0°C , the mercury thread is of length 3cm and 11cm at 100°C . What would be the length of the thread if the bulb of the thermometer is dipped in oil whose temperature is 80°C ? (2mks)

(2mks)

c) The graphs below show the cooling curves obtained when water at 80°C was poured into two identical cans A and B painted silver and black on their outside respectively.

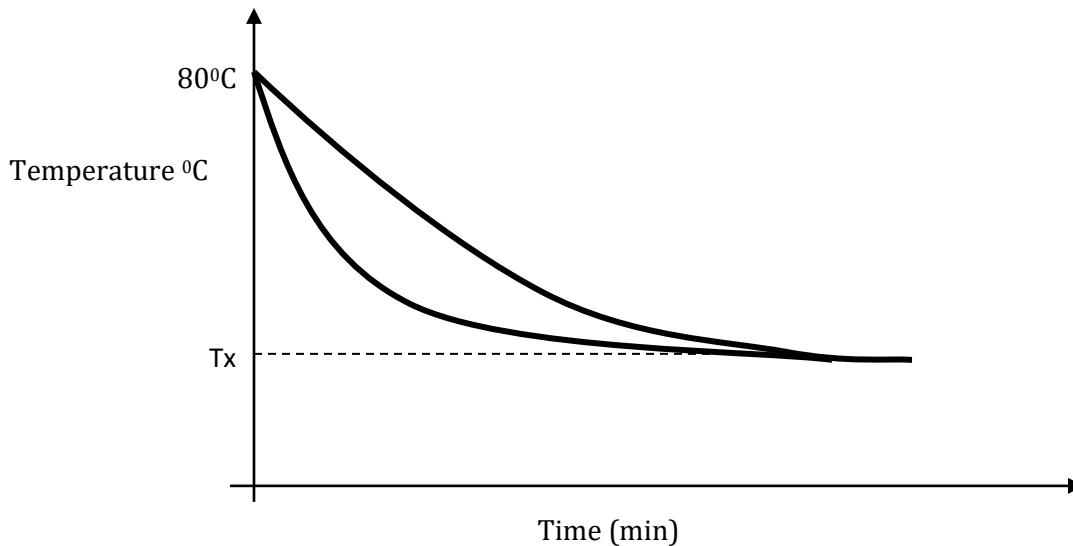

i. On the graph, name the curve T_B for the can B. (1mk)

.....

ii. Identify the temperature T_x . (1mk)

.....

iii. Name the mode of heat transfer tested above. (1mk)

.....

iv. Apart from length of the material and its cross section area, name two other factors on which conduction depends. (2mks)

.....

.....

.....

v. Why are gases generally poor conductors of heat? (1mk)

.....

.....

15.

a) Define specific latent heat of fusion of ice. (1mk)

.....

.....

.....

b) Ice cube of mass m at 0° float in water of mass 100 g at 0° contained in a copper calorimeter of mass 50 g . Steam of mass 60 g at 100° is passed through the mixture until a temperature 40° is attained. (Specific latent heat of vaporization of water is $2.26 \times 10^6\text{ J/kg}$, specific latent heat of fusion of ice is $3.34 \times 10^5\text{ J/kg}$, specific heat capacity of water is $4.2 \times 10^3\text{ J/kg/K}$ and specific heat capacity of copper is 400 J/kg/K).

Determine the;

i. Quantity of heat lost by steam to condense to water and cool to 40° . (3 mks)

ii. Quantity of heat absorbed by ice, water and calorimeter to raise its temperature to 40° . (3 mks)

iii. Mass m of ice that melted at 0° . (3 mks)

16.

a) The moon goes round the earth at constant speed. Explain why it is true to say that the moon is accelerating. (1mk)

.....
.....

- b) A string of negligible mass has a bucket tied at the end. The string is 60m long and the bucket has a mass of 45g. The bucket is swung horizontally making 6 revolutions per second. Calculate the centripetal acceleration of the bucket. (3mks)

- c) The figure below shows a body of mass $m = 200\text{g}$ attached to the centre of a rotating table with a string. The radius of the string was varied and different values of angular velocity recorded. the mass of the body remained constant throughout the experiment.

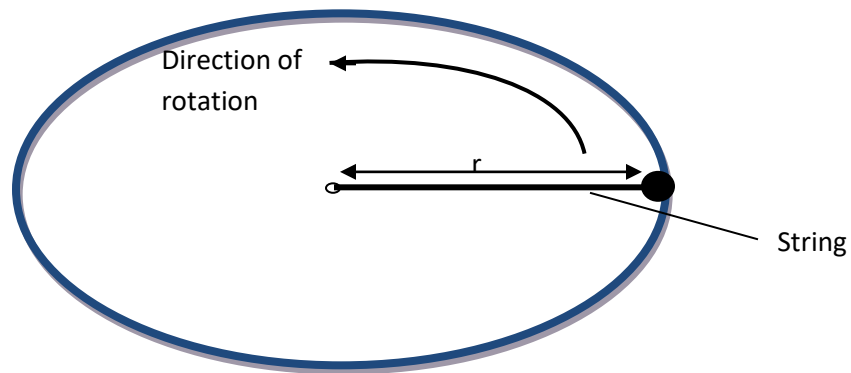

The results obtained for angular velocity and radius were used to plot the following graph.

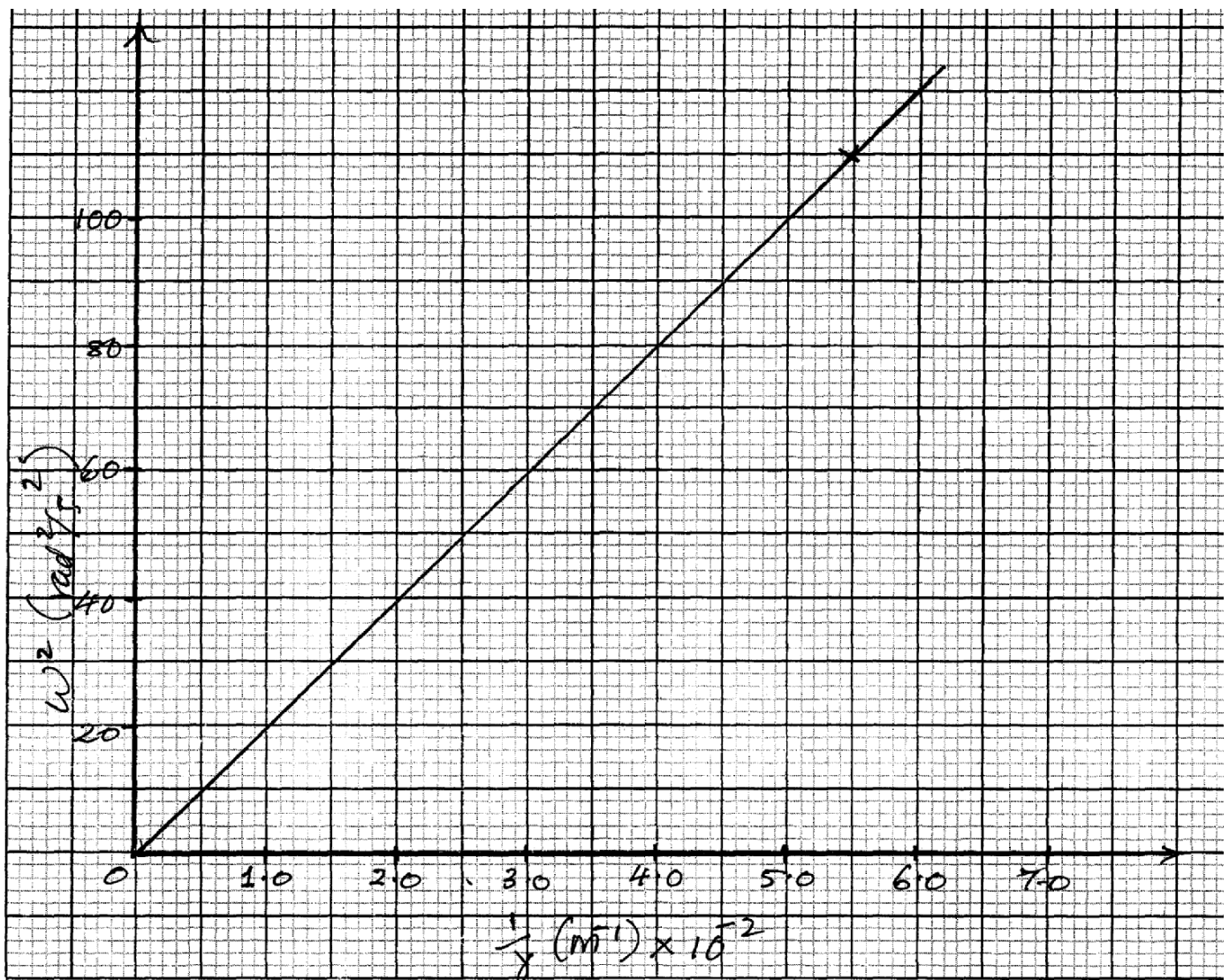

From the above graph.

i. Calculate the value of the slope. (2mks)

ii. If ω^2 and $\frac{1}{r}$ are related by the equation $\omega^2 = \frac{P}{r} \times \frac{1}{m}$, find the value of P. (3mks)

iii. State the significance of P. (1mk)



BUTERE GIRLS' NATIONAL SCHOOL

MOCK EXAMS 2025



Kenya Certificate of Secondary Education

NAME..... INDEX NO.:.....

STREAM: ADM NO:

PHYSICS

Paper 232/2

(THEORY)

Time: 2 Hours

INSTRUCTIONS TO CANDIDATES:-

- Write your **Name**, **Index number**, **Admission number** and **school** in the spaces provided above.
- This paper consists of **two** sections; **A** and **B**
- Answer **all** the questions in section **A** and **B** in the spaces provided.
- This paper consist of 19 printed pages. You are advised to ascertain that all pages are printed as indicated.
- Take the earth's gravitational field strength $g = 10 \text{ m/s}^2$.

For Examiner's Use Only:

SECTION	QUESTION	TOTAL SCORE	CANDIDATES SCORE
A	1 - 12	25	
B	13	10	
	14	9	
	15	8	
	16	9	
	17	9	
	18	10	
TOTAL		80	

SECTION A (25 MARKS)

Answer all questions in this section in the spaces provided.

1. The diagram below shows two parallel mirrors M_1 and M_2 and a ray of light being incident on one of the mirrors as shown.

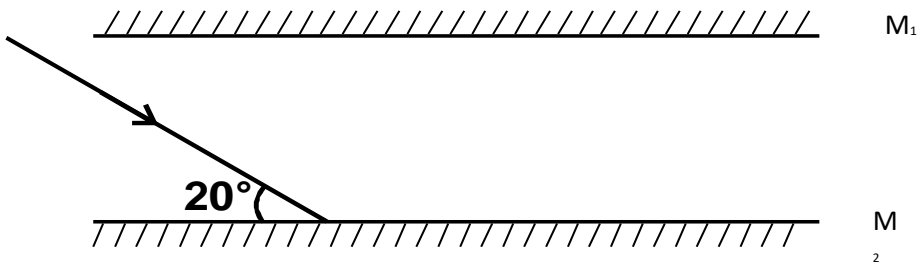

Trace the ray of light through the mirrors and indicate the angle of incidence on M_1

(2 mks)

2. Two pins are hanging from a magnet as shown in the diagram below.

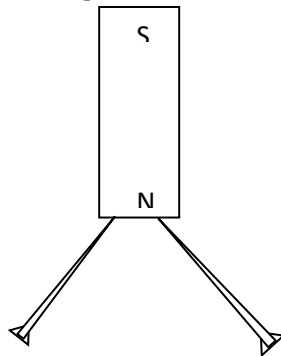

Explain why the pins spread as shown in the diagram.

(2mks)

.....

.....

.....

3. An image I is formed in front of a concave mirror and on the principal axis as shown in the figure below.

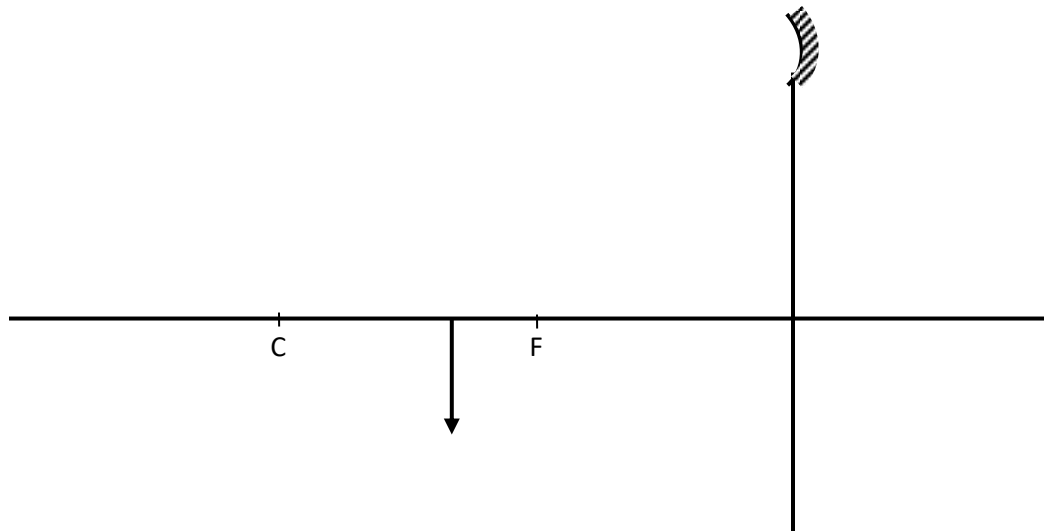

4. The figure below shows a set up by a student.

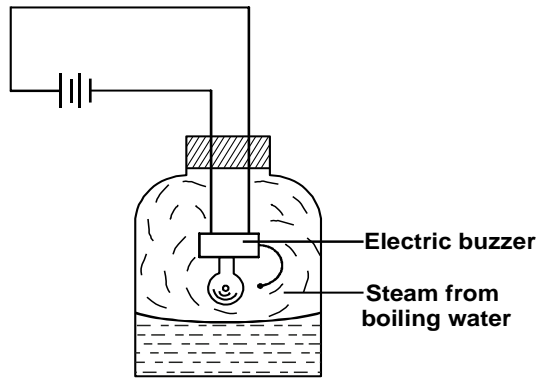

State and explain what happens to the sound from the buzzer as the bottle and its contents are cooled to 0°C . (2 mks)

.....

.....

.....

5. Arrange the following waves in order of decreasing wavelength. (1mk)

Infrared, X-rays, Microwaves, Radio waves, Red light.

.....

.....

6. Figure below shows an incomplete circuit of an electromagnet.

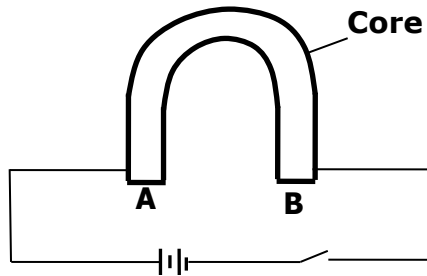

Complete the circuit by drawing the windings on the two arms of the core such that A and B are both North poles when the switch is closed. (1mk)

7. Figure represents a step in charging a material B negatively by induction.

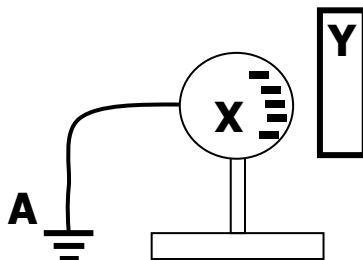

(i) What is the charge on Y? (1mk)

(ii) Explain what happens at A. (1mk)

8. The graph below shows the variation of p.d. (V) across the terminals of a cell and current drawn from the cell.

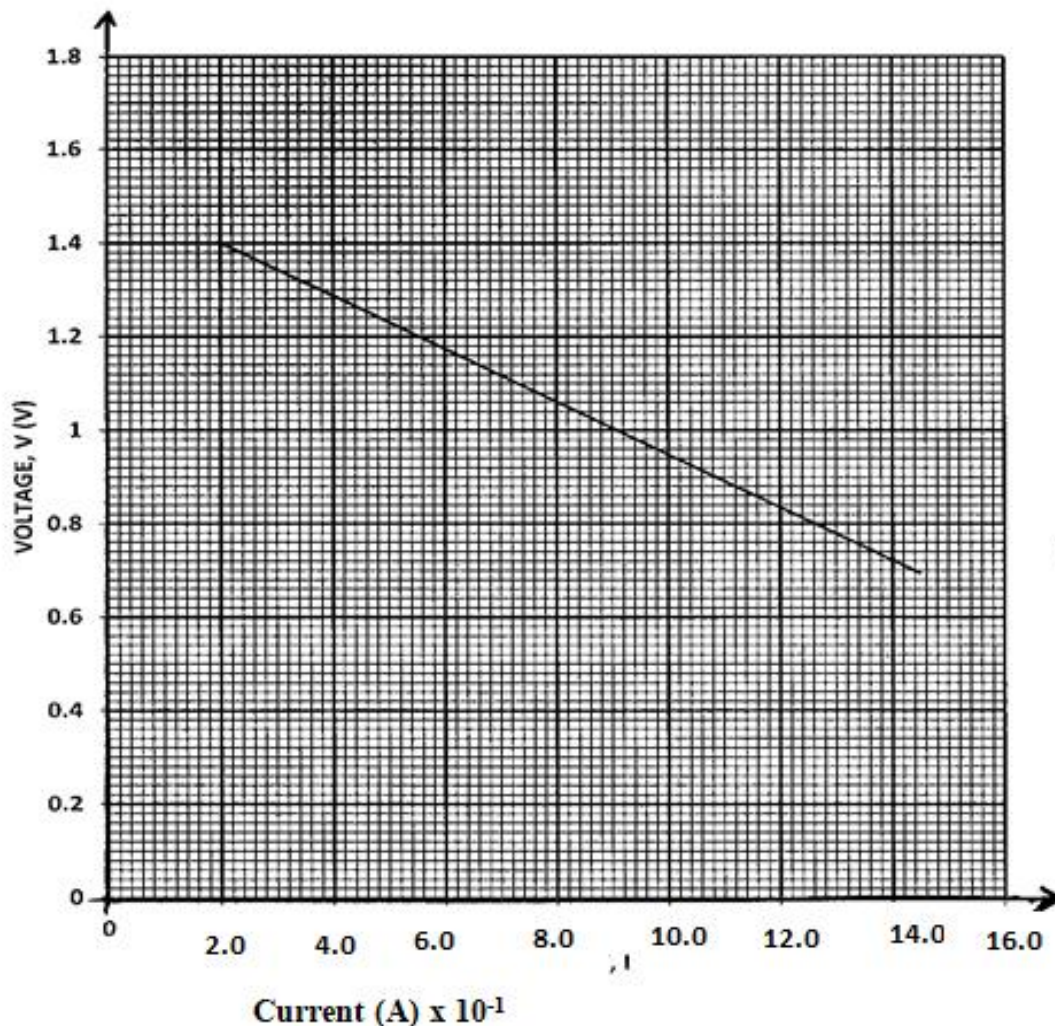

a) Use the graph to determine the electromotive force (emf) of the cell. (1mk)

b) Draw a circuit diagram that may be used to obtain the values plotted in the graph. (2mk)

9. A vibrator is sending out eight ripples per second across a water tank. The ripples are observed to be 4cm apart. Calculate the velocity of the ripples. (3mks)

10. The figure below shows part of electric cooker coil.

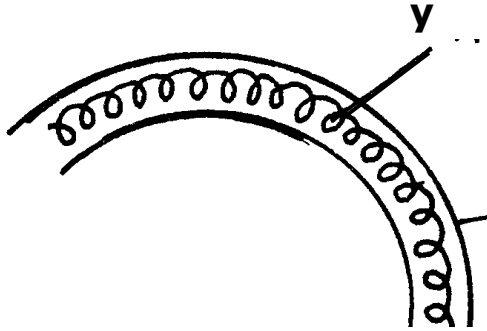

- i. Why is the material labeled Y coiled? (1mk)

.....

- ii. State the property of material Y that makes it suitable for its use. (1mk)

.....

.....

11. An immersion heater rated 1500W is used continuously for 30 minutes per hour per day. Calculate the cost of electricity per week if the rate is Ksh. 6.70 per unit. (2mks)

12. Fig below shows a conductor y placed in a magnetic field. The conductor carries a current flowing into the paper.

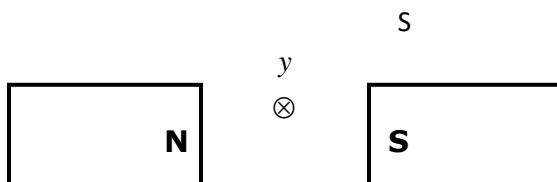

- (i) Sketch the resultant magnetic field between the poles of the bar-magnet.

(1mk)

(ii) Show on the diagram the direction of the force, F acting on the conductor

(1mk)

SECTION B (55 MARKS)

Answer all questions in this section in the spaces provided.

13.

a) Figure below shows the path of light through a transparent material placed in air.

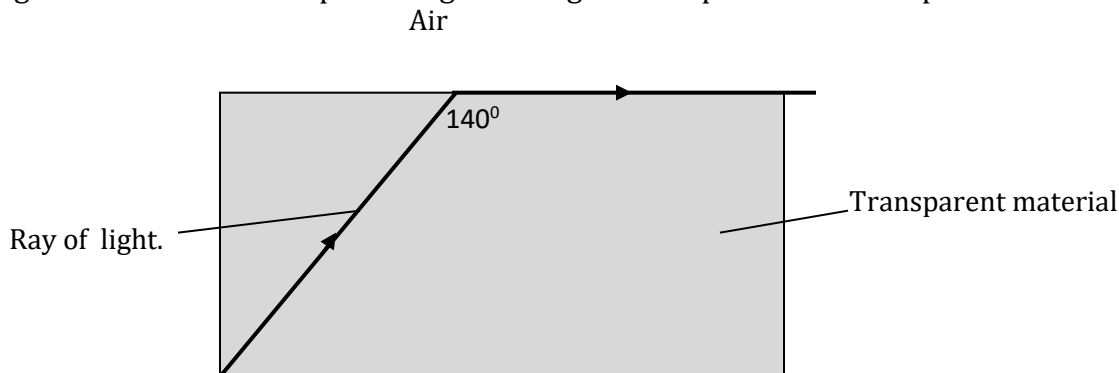

i. Give a reason why the above ray is not refracted at the interface of air and the transparent material as shown in the diagram. (1mk)

.....
.....

ii. Calculate the refractive index of the transparent material. (3mks)

b) An image is formed 10cm in front of a concave lens of focal length 15cm. calculate the position of the object in respect to the lens. (3mks)

c) You are provided with the following apparatus to determine the focal length of a lens.

- A lit candle.
- A white screen.
- A metre rule.

With a aid of a labelled diagram, describe the procedure you would follow to determine the focal length of the lens. (3mks)

14.

- a) The figure below shows metal plates X and Y each fixed to an insulated stand. X is charged and Y is earthed. X is connected to an uncharged electroscope with a conductor.

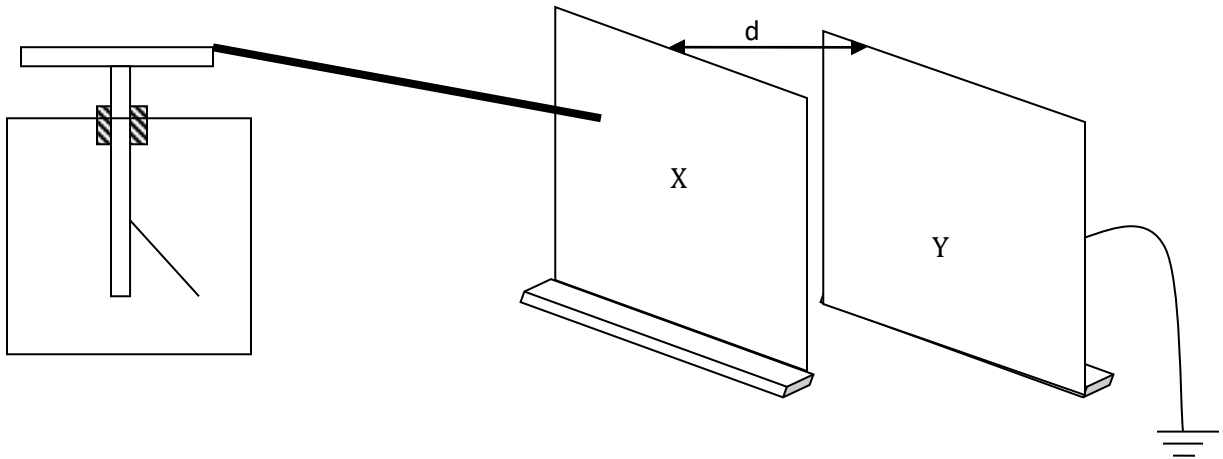

If plate Y is moved away from plate X,

- i. State what happens to the amount of charge on the plates. (1mk)

.....

- ii. State and explain the observation made. (3mks)

.....

.....

.....

.....

- b) The figure below shows an arrangement of capacitors connected to a 12V dc supply.

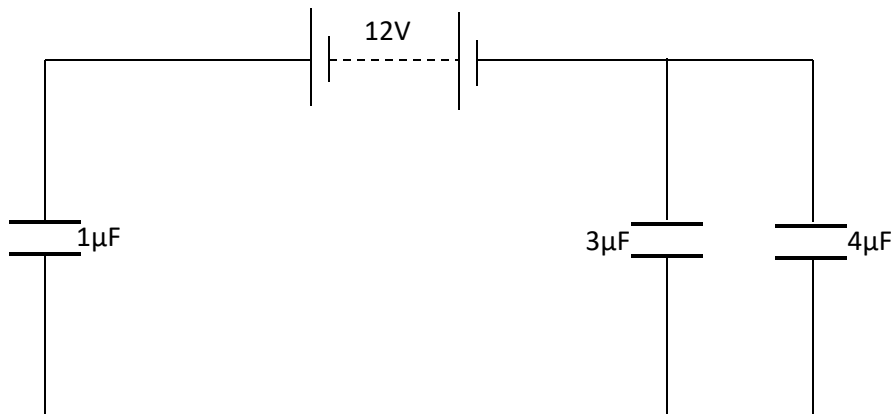

Determine:

- i. The total capacitance of the arrangement. (2mks)

.....
.....

- ii. The voltage across the $3\mu\text{F}$ capacitor. (3mks)

15.

- a) The figure below shows an attempt to supply each of the three lamps L1, L2 and L3 with a switch.

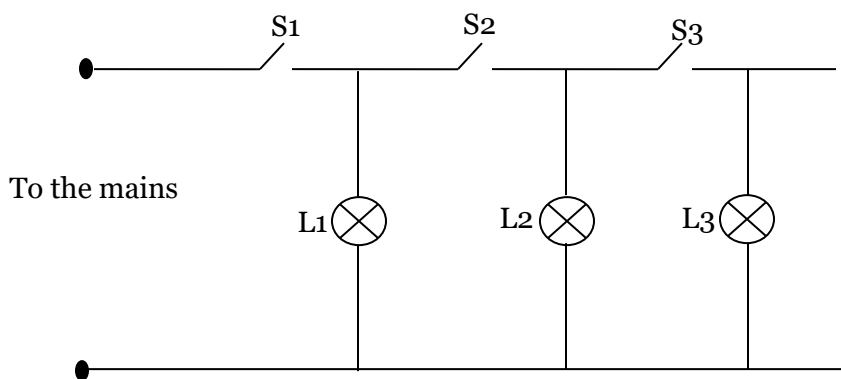

- i. Give a reason why this is a poor connection. (1mk)

.....
.....

- ii. Redraw the diagram to show the correct positioning of the switches. (1mk)

b) A wire placed between the pole of two permanent magnets is connected to a galvanometer as shown below.

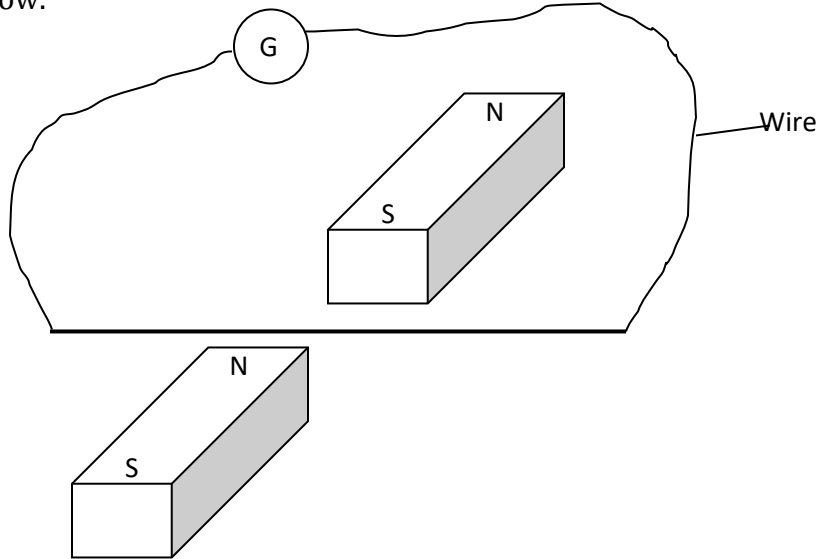

i. State what is observed when the wire is moved up and down. (2mks)

.....

.....

.....

ii. Suggest two ways of increasing the magnitude of the effect you have stated in (i) above. (2mks)

.....

.....

.....

iii. The figure below shows a simple transformer. Study it and answer the questions that follow.

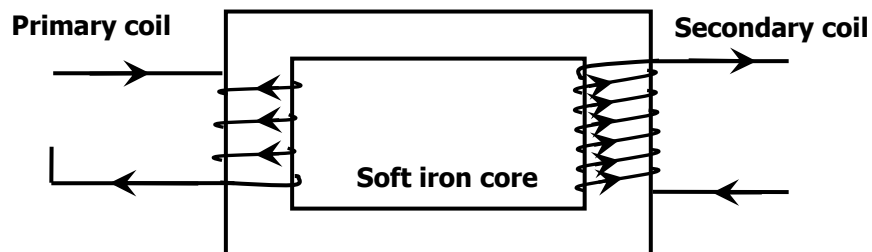

State and explain which coils are thicker. (2mks)

.....

.....

.....

16.

a) The figure below shows Zinc plate placed on the cap of a negatively charged electroscope.

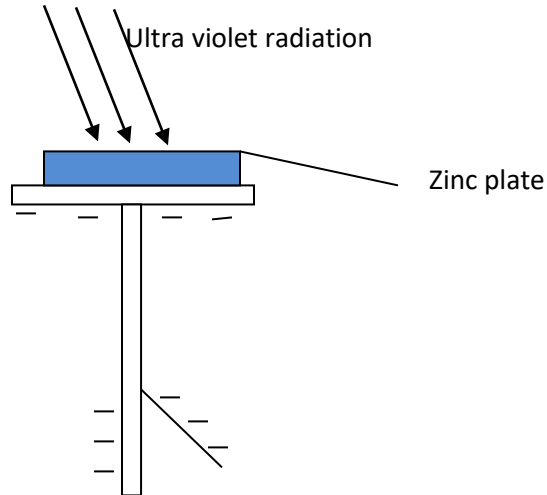

Ultraviolet radiation is made to fall on the plate as shown on the diagram.

i. What happens to the leaf of the electroscope? (1mk)

.....
.....
.....

ii. What would happen if radiation was red light? (1mk)

.....
.....
.....
.....

- b) In an experiment to find the relationship between frequency of a radiation and kinetic energy of the photoelectrons in a photoelectric device, the following graph was obtained.

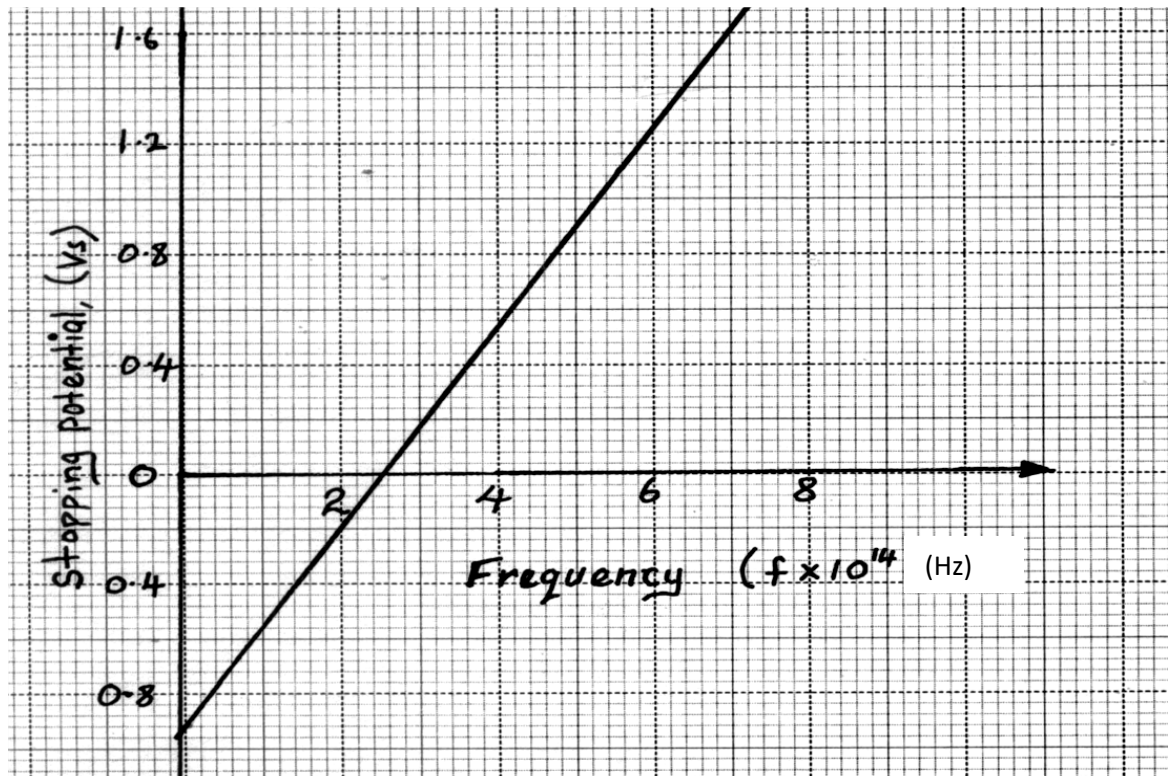

Use the graph to determine the Planck's constant h .

(3mks)

c) Figure below shows the features of an X-ray tube.

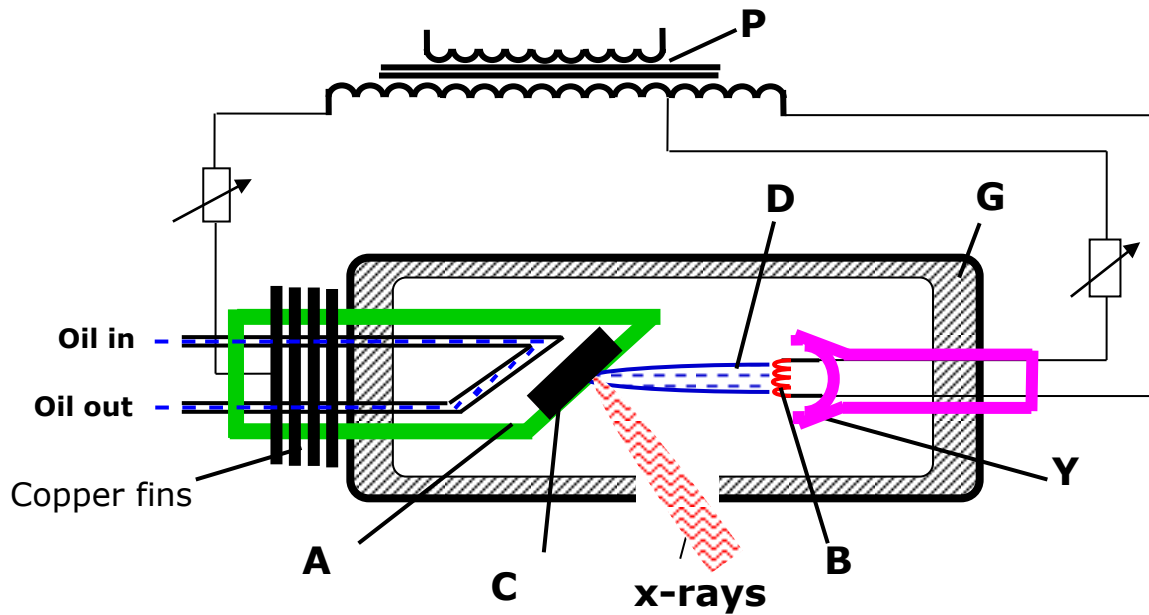

i. Explain the function of part labelled P.

(1mk)

.....

ii. Explain why the part labelled C gets very hot during production of X-rays.

(2mks)

.....

iii. Explain what is done to produce X-rays of shorter wavelength using the above X-ray tube.

(1mk)

.....

17.

a) The figure below shows monochromatic source of light L behind a barrier with a single slit S placed behind another barrier with two identical slits S_1 and S_2 . A screen PQ is placed in position as shown.

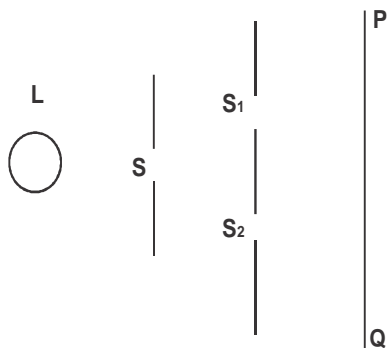

i) What is the significance of S_1 and S_2 ? (1 mk)

.....
.....

ii) Explain what is observed on screen PQ. (2 mks)

.....
.....
.....
.....

b) Waves pass from deep water to shallow water and refraction occurs.

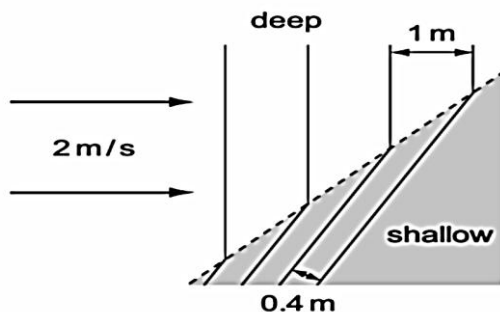

Calculate the speed of the waves in the shallow water. (2 mks)

c) The figure below shows an a.c. signal on the screen of a Cathode Ray Oscilloscope.

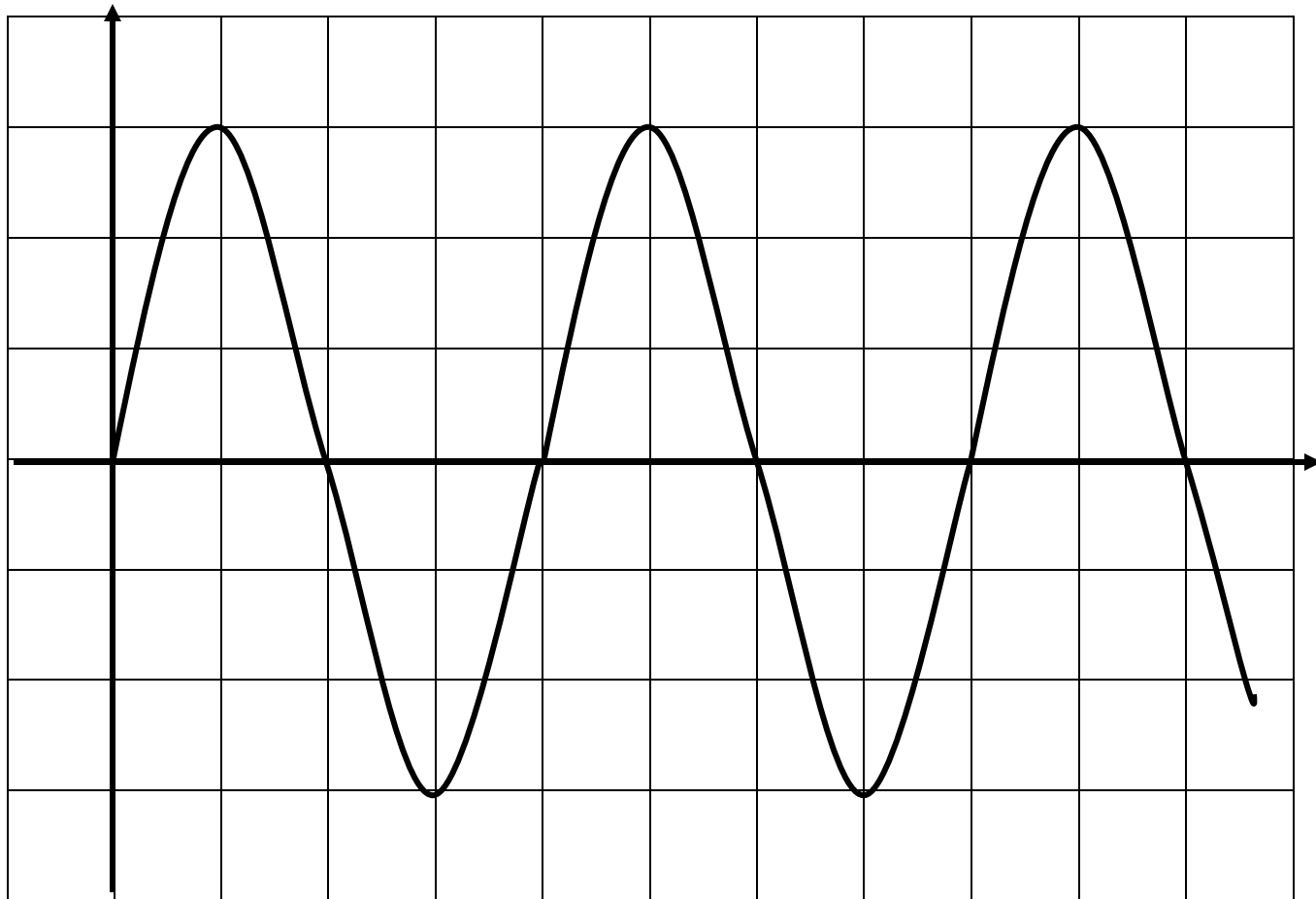

Determine the frequency of the signal given that the time base is set at 10ms/division.

(2mks)

d) Diagram (a) below shows the position of the bright spot on the screen of a C.R.O. when there is no signal on both Y and X plates.

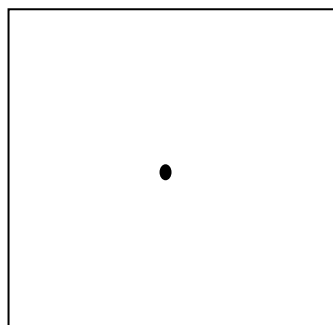

(a)

Indicate on the diagram (b) below what is observed on the display screen when the Y-plate is connected to a.c. signal and for (c) when X-plate is connected to a d.c. signal. (2mks)

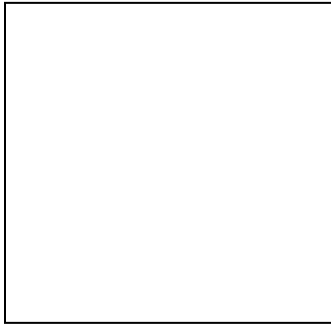

(b)

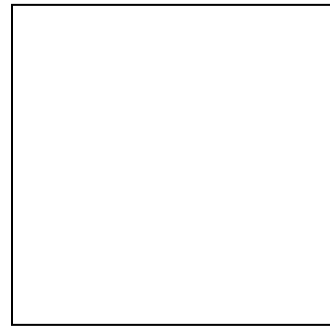

(c)

18.

a) The following reaction is part of a radioactive series.

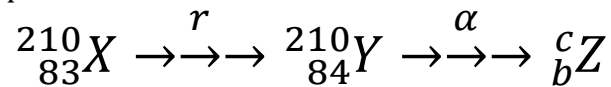

i. Identify the radiation r. (1mk)

ii. Determine the value of c. (1mk)

b) At a certain instant the corrected count-rate registered on a detector placed close to an α -particle emitter is 200 per second and this falls to 50 per second in 12 minutes. Determine the half life of the source. (3mks)

c) Study the rectification circuit below and use it to answer questions that follow.

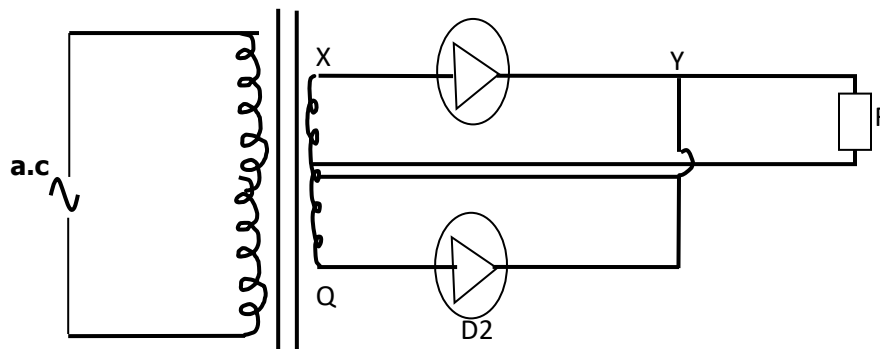

i. Briefly explain how the circuit works to rectify the alternating current. (3mks)

.....

.....

.....

.....

.....

ii. Show on the diagram how a capacitor should be connected to smooth the output voltage. (1mk)

iii. In the grid provided, sketch a curve of smoothed output voltage against time. (1mk)

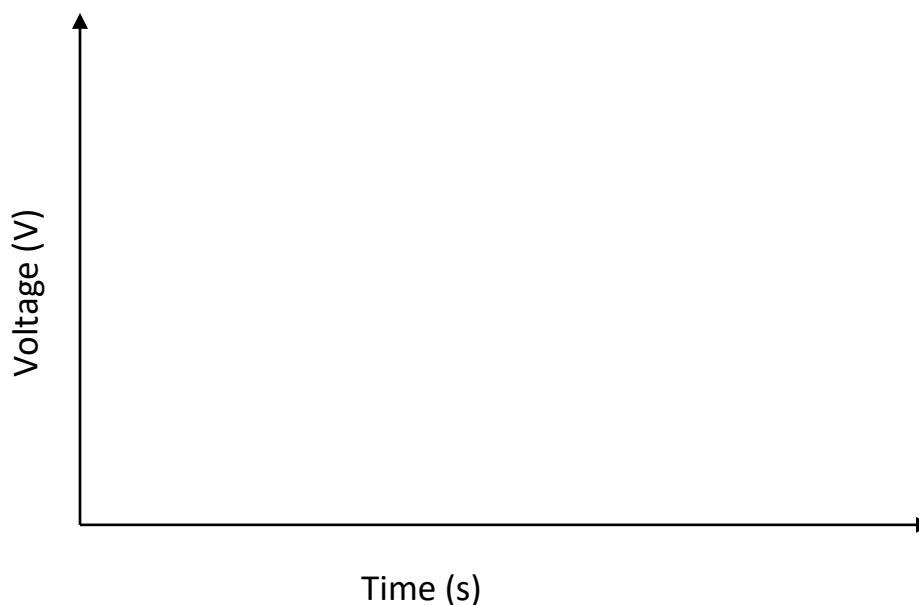



BUTEREGIRLS' NATIONALSCHOOL

MOCK EXAMS 2025



Kenya Certificate of Secondary Education

NAME..... INDEX NO.:.....

STREAM: ADM NO:

DATE:

232/3

PHYSICS

Paper 3(PRACTICAL)

Time: 2 .5 Hours

Kenya Certificate of Secondary Education (K.C.S.E)

INSTRUCTIONS TO CANDIDATES: -

- Write your **name**, **index number** and **school** in the spaces provided above.
- Answer all the questions in the spaces provided above.
- You are supposed to spend the first 15 minutes of the 2 ½ hours allowed for this paper reading the whole paper carefully before commencing your work
- Marks are given for a clear record of the observations actually made their suitability, accuracy and the use made of them.
- Candidates are advised to record their observations as soon as they are made.
- Non- programmable silent calculators and KNEC Mathematical tables may be used.

QUESTION	PART	MAXIMUM SCORE	CANDIDATE'S SCORE
1	A	05	
	B	15	
2	A	10	
	B	10	
		40	

QUESTION 1

You are provided with the following apparatus;

- A carbon resistor labelled X.
- A carbon resistor labelled Z
- A voltmeter (0 – 5V)
- An ammeter (0 – 1A)
- 5 10Ω carbon resistors.
- Centre zero galvanometer.
- 2 new dry cells and cell holder.
- 8 connecting wires at least 4 with crocodile clips at one end.
- Jockey
- A resistance wire labelled AB mounted on mm scale.
- A switch.

PART A

a) Set up the circuit below.

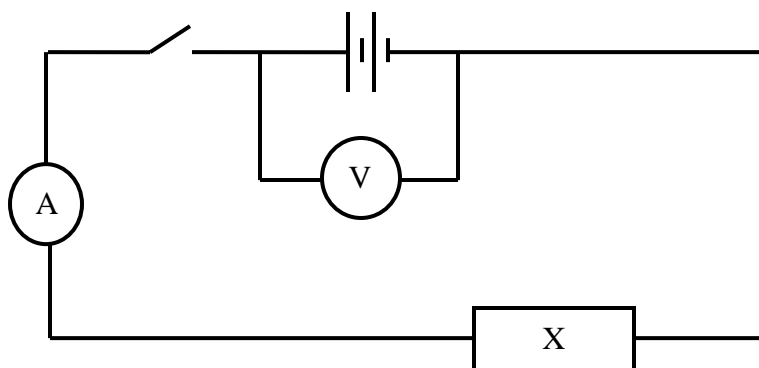

b) Record the voltmeter reading E when the switch is open.

E =V (1mk)

c) Close the switch and record the voltmeter and Ammeter readings V and I respectively.

V =V (1mk)

I =A (1mk)

d) Account for the difference between E and V. (1mk)

.....
.....

e) Calculate the resistance R for resistor X. (1mk)

PART B

a) Set up the circuit as shown in the figure below.

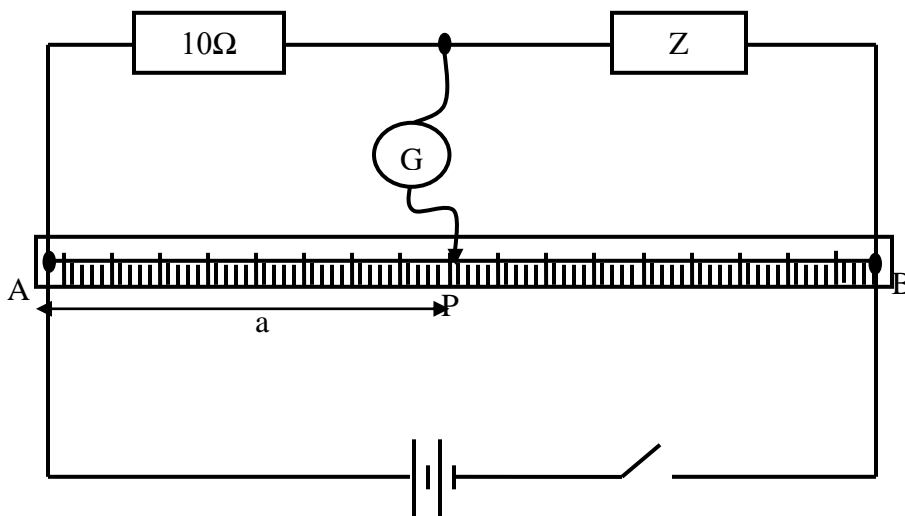

- b) Close the switch. Tap the jockey at various points on the wire AB and locate point P at which the galvanometer shows zero deflection. Measure and record in the table below the length a where $a = AP$.
- c) Repeat procedure b) using two 10Ω resistors in series, then three resistors in series, then four resistors in series and five resistors in series.
- d) Record your readings in the table below and complete the table where X is the effective resistance for the series combination. (5mks)

Number of 10Ω carbon resistors	One	Two	Three	Four	Five
X (Ω)					
a (cm)					
$1/X$ (Ω^{-1})					
$1/a$ (cm^{-1})					

e) Plot a graph of $1/a$ (cm^{-1}) against $1/x$ (Ω^{-1})

(5mks)

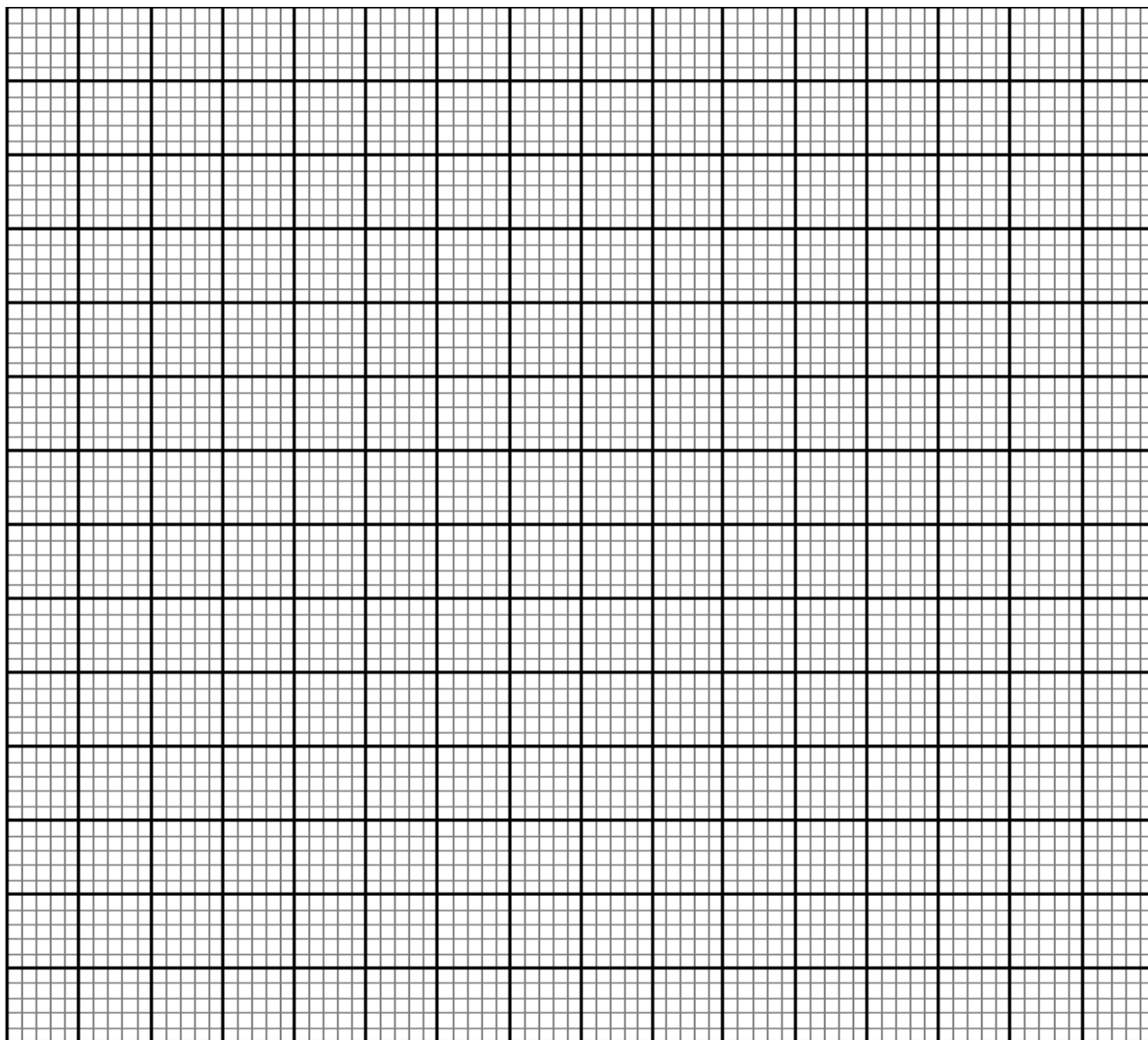

f) Determine the slope m of the graph.

(3mks)

g) Given that $\frac{1}{a} = \frac{R}{K} \cdot \frac{1}{X} + \frac{1}{K}$ where $K = 100\text{cm}$, use the graph to determine R .

(2mks)

QUESTION B

PART A

You are provided with the following;

- Metre rule.
- Screen
- Glass beaker (250ml)
- Water plasticine.
- A candle.

Proceed as follows;

- a) Add a volume $V= 200\text{ml}$ of water into the beaker.
- b) Measure the value of h , the height of water in the beaker.

$h = \dots\dots\dots\text{cm}$ (1mk)

- c) Calculate the value of internal radius R of the beaker using the formula $R = \sqrt{\frac{V}{\pi h}}$ where

$\pi = \frac{22}{7}$

(2mks)

$R = \dots\dots\dots$

- d) Fill the beaker with water and set the apparatus as shown below.

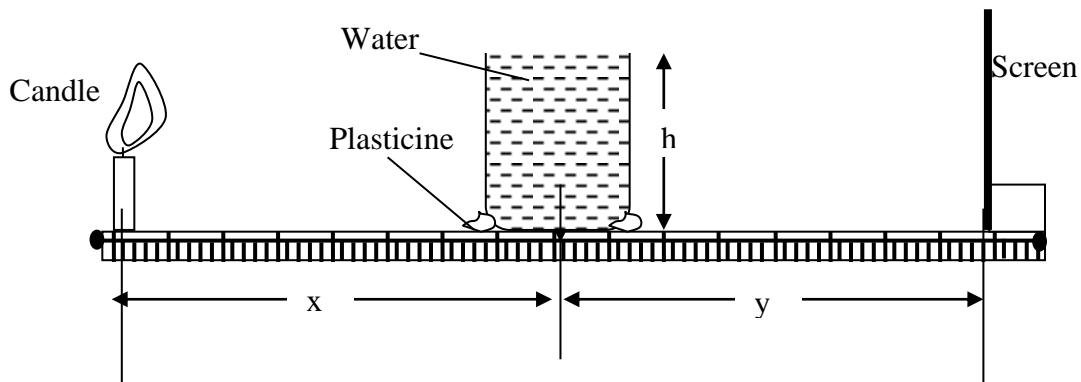

- e) Position the candle which acts as an object above the metre rule and $10R$ from the centre of the water 'lens'.

- f) Measure the object distance x . (1mk)

$x = \dots\dots\dots\text{cm}$

g) Move the screen towards or away from the water lens to obtain a sharp and focused bright image (line) on the screen.

h) Measure the value of image distance y . (1mk)

$y = \dots\dots\dots\text{cm}$

i) Repeat the experiment for the other values of x in the table below and note and record the corresponding values of y . Complete the table.

Beaker position	10R	9R	8R
x			
y			
$S = \frac{xy}{x + y}$			

I. Determine the average value of S . (2mks)

II. What does S represent. (1mk)

PART B

You are provided with the following;

- Vernier calipers. (can be shared)
- Micrometer screw gauge (can be shared)
- Boiling tube.
- Test tube.
- Some water in a beaker
- Half metre rule.
- 2 ball bearings.
- Some sand.
- Spatula
- Complete retort stand.

i. Measure and record the diameter of one ball bearing using the micrometer screw gauge.

$d = \dots\dots\dots\text{mm}$ (1/2mk)

ii. Determine the volume V of the ball bearing. (1mk)

$V = \dots\dots\dots\text{cm}^3$

- iii. Measure and record the outer diameter D of the test tube using the vernier calipers.
 $D = \dots\dots\dots$ (1/2mk)
- iv. Calculate the cross-sectional area A of the tube. (1mk)

$A \dots\dots\dots\text{cm}^2$

- v. Mount the boiling tube on the clamp as shown below and put some water to a height of about 8.5cm from bottom.

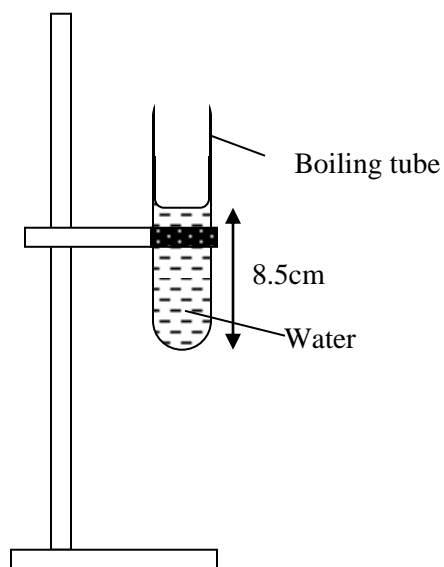

- vi. Gently lower the test tube into the water in the boiling tube.
- vii. Add some sand into the test tube bit by bit until the test tube floats upright in the water.
- viii. Note and record height h_0 of the water in the boiling tube from the bottom.

$h_0 = \dots\dots\dots\text{cm}$ (1mk)

- ix. Gently lower one ball bearing into the test tube and note and record the new level h in the table below.
- x. Add the other ball bearing and note and record the corresponding height h .
- xi. Compute the values of $h - h_0$ and complete the table. (2mks)

No. of ball bearings (N)	Height h (cm)	$h - h_0$ (cm)
1		

xii. Calculate S the average value of X where $X = \frac{h - h_0}{N}$ (1mk)

xiii. Given that $S = \frac{V\ell_s}{A\ell_e}$

where ℓ_s is the density of steel and ℓ_e the density of water, determine the ratio of

$$\frac{\ell_s}{\ell_e} \quad (2mks)$$

xiv. What is the significance of the ratio $\frac{\ell_s}{\ell_e}$ (1mk)

THIS IS THE LAST PRINTED PAGE!